

SAFE *CLEANBOX*

USER AND MAINTENANCE MANUAL

MODEL: STK 100

SERIAL N.: BM_____



DISCLAIMER

This document is the exclusive property of BICARjet S.r.l., all rights are reserved. Any disclosure, copying or transfer of the content to third parties is prohibited without the prior authorization of the Company.

BICARjet S.r.l. does not accept any liability for injury to persons or damage to property resulting from the misuse of this product or from failure to follow the directions, warnings, instructions and precautions reported in this user manual.

This user manual is provided in hardcopy format only and should always accompany the SAFE CleanBox model STK 100 device.

SAFE CleanBox is manufactured by:

BICARjet S.r.l.
Registered office - Via Nona Strada, 2 - 35129 Padova, Italy
VAT NUMBER: 03735720280

CONTENTS

DISCLAIMER	2
1 GENERAL INFORMATION	6
1.1 INTENDED USE.....	6
1.2 CLASSIFICATION	6
1.3 SYMBOLS	7
1.4 PRELIMINARY WARNINGS	7
1.5 GENERAL SAFETY RECOMMENDATIONS:	7
1.6 RECOMMENDATIONS REGARDING LIGHTING AND VENTILATION OF THE PREMISES.....	10
1.7 CONNECTIONS.....	10
1.7.1 <i>Electrical connection</i>	10
1.7.2 <i>Compressed air connection</i>	10
1.7.3 <i>Water connection</i>	10
1.7.4 <i>Drain connection</i>	10
1.8 SAFETY DEVICES	11
1.9 COMPOSITION OF THE DEVICE	15
2 INSTALLATION	18
2.1 LIFTING AND TRANSPORT	19
2.2 SET-UP OF USE ENVIRONMENT	20
2.3 PREPARATION FOR INSTALLATION	20
2.3.1 <i>Preparation of the electrical system</i>	21
2.3.2 <i>Preparation of the compressed air system</i>	21
2.3.3 <i>Preparation of the water system</i>	21
2.3.4 <i>Preparation of the drainage system</i>	22
2.3.5 <i>Preparation of the work area</i>	22
2.4 POST-INSTALLATION CHECKS	22
3 METHOD OF USE	24
3.1 SWITCHING ON THE DEVICE.....	24
3.2 START-UP AND OPERATION - LOGIN	24
3.2.1 <i>CREATION OF NEW OPERATOR</i>	26
3.2.2 <i>OPERATION OF THE DEVICE:</i>	28
3.2.3 <i>OPENING THE CABIN</i>	28
3.2.4 <i>START CLEANING OF THE INSTRUMENTS</i>	29
3.2.5 <i>INSTRUMENT TREATMENT PROCEDURE</i>	30
3.2.6 <i>INSTRUMENT RINSING PROCEDURE</i>	30
3.2.7 <i>INSTRUMENT BLOWING PROCEDURE</i>	31
3.2.8 <i>MATERIALS COMPATIBLE WITH THE TREATMENT</i>	31
3.3 END.....	32
3.4 NOTIFICATIONS / ALARMS.....	34

3.4.1	ALARM GUIDE.....	35
3.5	REPLACEMENT OF CONSUMABLES	36
4	MAINTENANCE.....	38
4.1	ROUTINE MAINTENANCE	38
4.2	PREVENTIVE MAINTENANCE	43
4.3	NON-ROUTINE MAINTENANCE AND REPAIRS.....	44
4.4	POST-MAINTENANCE CHECKS	46
4.5	TECHNICAL ASSISTANCE.....	46
4.6	WARRANTY TERMS AND CONDITIONS.....	46
5	CLEANING	47
6	DISPOSAL.....	47
7	TECHNICAL FEATURES.....	47
8	LABELLING	48
8.1	RATING PLATE INFORMATION	48
8.2	INTERNAL MARKINGS	48
8.3	WATER SUPPLY, COMPRESSED AIR AND DRAINAGE	48
8.4	WARNING MARKINGS.....	49
8.5	SAFETY SYMBOLS AND LABELLING.....	49
9	ELECTROMAGNETIC COMPATIBILITY	51
9.1	EMC WARNINGS	51
10	TUTORIAL ON CORRECT CLEANING OF THE INSTRUMENTS	52
10.1	DRILL TUTORIAL.....	52
10.2	SHIELDED CABLE - 296-4 05168	53
10.3	SHIRT FOR LAPAROSCOPIC (CANNULATED) INSTRUMENTS	53
10.4	PROCEDURE FOR CANNULATED INSTRUMENTS	54
10.5	MONOPOLAR INSULATED FORCEPS	56
10.6	VICKERS ELEVATOR - KLS MARTIN 23-506-17	56
10.7	BONE FORCEPS - SYNTHES 398.81	57
10.8	BIPOLAR FORCEPS - SOFAR 82410001 / BISSINGER 82410034	58
10.9	TEMPORARY COVER - STORZ 27 026 UO	60
10.10	MONOPOLAR HOOK FOR COAGULATION	61
10.11	BIPOLAR FORCEPS - MICRO FRANCE CEV 136.....	62
10.12	MONOPOLAR FORCEPS - REMA 28 - 247 - 000	64
10.13	CYSTOSCOPY SHIRT - STORZ 27 026 B.....	65
10.14	OBJECT ENTIRELY IN METAL. TREAT WITH THE JET IN FULL	65
10.15	OBJECT X - MITEK 214615.....	67
10.16	ARTHROSCOPY FORCEPS - MITEK 214602	68
10.17	KARL STORZ TROCAR 30160 H2 (CANNULA WITH STOPCOCK)	70
10.18	EYE MICROSURGERY KIT - STEEL.....	72
10.19	KARL STORZ ROD-LENS SYSTEM 27005AA.....	73

11	SW MANUAL - HMI PANEL.....	74
11.1	MACHINE READY - HOME SCREEN	74
11.2	LAVAGGIO ATTIVO (ACTIVE WASHING) SCREEN	74
11.3	RISCIACQUO ATTIVO (ACTIVE RINSING) SCREEN	75
11.4	MACCHINA IN EMERGENZA (MACHINE IN EMERGENCY MODE) SCREEN	75
11.5	SETTINGS/MENU SCREEN	76
11.6	SISTEMA (SYSTEM) SCREEN	76
11.7	DATE AND TIME SETTING SCREEN	77
11.8	DIAGNOSTICA (DIAGNOSTICS) SCREENS	78
11.9	PARAMETRI (PARAMETERS) SCREEN	79
11.10	CICLO PROVA (TEST CYCLE) SCREENS.....	80
11.11	REGISTRO ALLARMI (ALARMS REGISTER) SCREEN	80
12	ANNEX 01: PRE-SET USERS/PASSWORDS.....	81
13	ANNEX 02: HOSE CONNECTIONS INSIDE THE CABIN.....	82

1 GENERAL INFORMATION

SAFE CleanBox is a medical device intended for sterilization centers/laboratories for the pre-treatment of DMRs (Reusable Medical Devices) and finds its functional location in the pre-washing phase of the DMRs before they undergo washing, disinfection and sterilization processes. The process is similar in outcome to highly effective and efficient mechanical brushing, and involves the use of a jet of compressed air and granular sodium bicarbonate to remove residues from the surfaces of the RMDs without causing structural damage. The sodium bicarbonate used (SAFEKLINIC brand) is totally soluble and is not classified as dangerous for the environment or for the operator.

The system consists of a cabin similar in design to a "glove box" equipped with gloves to manipulate the instruments without these coming into direct contact with the operator's hands, and the operations are confined in a closed environment for the benefit of the operator's safety and comfort.

Inside the cabin there are two handpieces; one for the bicarbonate treatment with compressed air with water and the other for rinsing with compressed air and water. The flanges placed on the front part of the cabin are oval in shape to satisfy the ergonomics necessary for the operator's comfort and allow for ample space for action, easily removable with a quick release system useful for changing gloves in case of first failure. The two handpieces are managed through a control with two independent pedals.

THE EFFECTIVENESS OF REMOVAL OF RESIDUES/CONTAMINANTS FROM RMDS IS GUARANTEED ONLY AND EXCLUSIVELY THROUGH THE USE OF SODIUM BICARBONATE, ACCORDING TO THE INSTRUCTIONS GIVEN IN CHAPTER 3.2.4.

1.1 INTENDED USE

The intended use is the preparation of the RMD for the washing process in the instrument washer. The action is carried out by bringing a jet of compressed air and bicarbonate in contact with the object to be treated, in order to remove any contaminant from the surface without damaging it and increase the effectiveness of the subsequent phases. This operation is conceptually similar to manual brushing of the RMDs, normally carried out prior to washing, disinfection and/or sterilization processes.

1.2 CLASSIFICATION

Classification according to Regulation (EU) 2017/745 Annex VIII rule 13 class I.



CAUTION!

THE DEVICE IS INTENDED TO BE USED BY SPECIALLY TRAINED OPERATORS IN RMD RECONDITIONING CENTRES WITHIN OR OUTSIDE HOSPITALS, AND IN LABORATORIES USED FOR THE NON-ROUTINE MAINTENANCE OF RMDS.

1.3 SYMBOLS



In order to make the reading of this manual simple and clear, the symbols used as important warnings for the correct and safe use of the device are shown below.



Requirement for correct use

This symbol precedes information for the correct use of the device.



Information requirement

This symbol precedes useful and general information, which guides the user in the informed use of the device and/or the performance of actions.



It indicates that the product has been designed and manufactured in compliance with the safety requirements of Regulation (EU) 2017/745 (Medical device class I and in compliance with classification rule 13 as indicated in Annex VIII).

1.4 PRELIMINARY WARNINGS

Failure to observe the following warnings and the rules and precautions described in this user manual will immediately void any warranty on the SAFE CleanBox device.

BICARjet S.r.l. is not liable for any injury to persons or damage to property resulting from failure to comply with the rules or precautions listed below and set out in general in this user manual.

The instructions or warnings are not intended to replace the accident prevention safety rules, but to supplement them and encourage compliance with them.

The employer must train the personnel in the risks of accidents, in the use of personal protective equipment, in the risks of noise emissions and in the general rules on the prevention of accidents provided for by international directives and by the legislation of the country of destination of the machinery. The operating, maintenance, cleaning and control personnel, etc. must therefore strictly comply with the accident prevention regulations of the country of destination of the machinery.

1.5 GENERAL SAFETY RECOMMENDATIONS:

BICARjet® S.r.l. has made every effort to design the **SAFE CleanBox** machine and to make it as **INTRINSICALLY SAFE** as possible.

The manufacturer has also equipped the machine with all the protective and safety devices considered necessary. Finally, it has provided enough information for it to be used safely and correctly.

In each chapter, the following information is provided for all human-machine interaction whenever necessary:

- The operator's minimum qualification required;
- The number of operators needed;
- The status of the system;
- The residual risks;
- The Personal Protective Equipment required or recommended;
- The prevention of human error;
- The prohibitions/obligations regarding reasonably foreseeable non-intended use/behaviour.

The user can integrate the information provided by the manufacturer with additional instructions to increase safety in using the system. Clearly this should not include information that contradicts information given in this instruction manual.

For instance, it is important to pay attention to the clothing of any person operating on the system:

- Do not wear loose clothing that could get caught on parts of the system;
- Do not wear ties or other loose garments;
- Do not wear bulky rings or bracelets that could get caught on parts of the system.

Whenever necessary, further recommendations for use will be provided in the Manual with regard to preventive measures, personal protective equipment, the prevention of human error and any reasonably foreseeable prohibited behaviour.

It is, however, essential to follow the instructions below carefully:

- It is strictly forbidden to operate the single machines that make up the system automatically with the fixed and/or movable guards removed;
- It is strictly forbidden to inhibit the safety devices installed on the system;
- The low safety operations must be carried out strictly in accordance with the instructions given in the relevant descriptions;
- Any protective devices of the system removed for the purpose of low safety operations must be put back in place as soon as possible;
- The washing operations must be carried out with the electrical and compressed air separation devices disconnected;
- Do not alter parts of the system for any reason; in the event of malfunction due to non-compliance with the above, the manufacturer cannot be held liable for the consequences. We recommend that you contact the manufacturer directly to request any alterations;
- Clean the casing of the machines, the panels and the controls with soft cloths that are dry or have been dampened with a mild detergent solution; do not use any type of solvent, such as alcohol or petrol, as the surfaces may be damaged;
- Position the machines following the instructions given at the time of order and referring to the diagrams provided by the manufacturer; if this is not done, the manufacturer cannot be held liable for any issues.

The safety officer of the company that owns the machine is required to ensure that the following safety warnings are read and understood correctly. The warnings below are divided into:

Safety obligations concerning general and organizational safety indications.

Warnings that apply to and must be known **by all personnel**. Intended for operation with or near the installation;

Warnings for operators with instructions which the operators of the installation must observe to ensure use of the machine without endangering their own safety or that of other operators or of property.

Everyone who, for whatever reason, finds themselves working in the work area of the machine, must read and understand the safety warnings.

Unauthorized tampering/replacement of one or more parts or units of the machine, the use of accessories, tools, consumables other than the original ones or in any case those recommended by the manufacturer, may represent a risk of injury and relieve the manufacturer from civil and criminal liability. The machine has been designed in such a way that all safety devices do not pose any risk for the operator.

The operator is strictly forbidden to alter the technical or physical characteristics of the equipment or to use it for purposes other than those foreseen and documented.

The machine must always be used according to the standards of good practice and the law in force in each country, even if the country of use does not have specific regulations that apply to the specific sector.

The manufacturer **BICARjet[®] S.r.l.** may be consulted regarding the possibility of carrying out non-routine work cycles not expressly provided for; in which case, the manufacturer will make its resources and expertise available to the customer.

In the case of any use other than that envisaged in the order and tested during the acceptance test, to which the machine may be put during its operating life, the user and/or operator is held solely responsible for any failures, environmental damage and harm to persons and property.

Environmental conditions and careful routine maintenance play a particularly important role for the correct and reliable operation of the machine.

There must be no harmful or chemically aggressive and/or explosive vapours and/or gases in the environment, and no infiltration of dust the extent and quality of which could be harmful to the operator or to the machine.

Cleaning the area around the machine is crucial to safety.

Dust and fragments of the product being processed or other residues can make the floor slippery, creating dangerous conditions.

Both the worktops and the floor must be cleaned regularly, using suitable equipment to remove dust, fragments and residues and any kind of foreign bodies.

It should always be borne in mind that the use of any machine can pose an element of risk.

Always focus all your attention on what you are doing.

It is essential to always take all due care and be alert at all times.

A person who experiences any discomfort or physical malaise, even slight, which can reduce their degree of vigilance, must avoid starting the machine or using the aggregate or accessory equipment. The operator must avoid unsafe operations not foreseen by the work in progress, which could compromise their own balance.

The operator is advised to use clothing suitable for the work environment and the situation concerned.

If necessary, the operator is advised to use protective goggles and personal hearing protection.

The person in charge of the machine or maintenance must avoid wearing chains, bracelets and rings and use a net to hold back long hair.

With regard to personal protective equipment, the European Community has issued directives 89/686/EEC and 89/656/EEC.

Variations with respect to normal operation (increase in power absorption, temperature, vibrations, noise or signals from the safety system) are clear indications of incorrect operation.

To prevent malfunctions, which can directly or indirectly cause serious damage to people or property, the maintenance personnel must be informed as a matter of urgency. Any maintenance on the hydraulic and compressed air systems must be carried out only after having released the pressure inside the systems themselves.

To resolve any cause of failure or inconvenience inherent in any element of the machine, take all suitable precautions to prevent any possible damage to people and property.

1.6 RECOMMENDATIONS REGARDING LIGHTING AND VENTILATION OF THE PREMISES

The customer must ensure ambient lighting to avoid the presence of shaded areas and risk of annoying glare. The lighting must be adequate for the planned operations.

Lack of lighting could pose risks.

An optimal ventilation of the premises must also be guaranteed, with the possible use, if foreseen, of an appropriate suction system.

1.7 CONNECTIONS

1.7.1 ELECTRICAL CONNECTION

Electrical supply: 220 V 50 Hz 16A

Power: 3.2 kW

Please observe the general rules for the preparation and installation of electrical systems: the earthing system must meet the specific characteristics defined by the CEI 64-8 standard.

Installation and electrical connections must only be carried out by qualified personnel.

The earth connection must also be made for low voltage systems located in normally wet or very humid places (if the voltage exceeds 25V to earth for alternating current and 50V to earth for direct current).

The earthing for protection of all parts of the system and all the earthing for operation of the circuits and appliances must be carried out by connecting the relevant parts to a single earthing system. Check that the materials used for the earthing system are sufficiently strong or have adequate mechanical protection.

Make the shortest possible connection to the main earth and ensure that the earth conductors are not subjected to mechanical stress or to the danger of corrosion.

1.7.2 COMPRESSED AIR CONNECTION

Air supply: 6 (min) to 10 (max) bar

Power line: DN 15 mm (1/2")

The supply air must be dehydrated, de-dusted and free from lubricating oils.

1.7.3 WATER CONNECTION

Water supply: 3 (min) bar

Power line: DN 15 mm (1/2")

1.7.4 DRAIN CONNECTION

Connection to the non-hazardous industrial waste water drainage system according to *Annex V part III of Legislative Decree no. 152/06*

Wall drainage line: Ø 40 mm

1.8 SAFETY DEVICES



FAILURE OR NEGLIGENCE IN COMPLYING WITH THE FOLLOWING INSTRUCTIONS MAY CAUSE THE DEVICE TO MALFUNCTION, CAUSE DAMAGE OR INJURY TO THE USER



IN ORDER TO PREVENT THE RISK OF ELECTRIC SHOCK, ONLY CONNECT THE DEVICE TO GROUNDED SOCKETS



DO NOT USE THE DEVICE UNTIL YOU HAVE READ AND UNDERSTOOD THIS USER MANUAL IN ITS ENTIRETY



DO NOT MODIFY THE DEVICE AND/OR ITS PARTS



USE OF THE DEVICE FOR PURPOSES OTHER THAN THOSE INDICATED IN THIS USER MANUAL COULD EXPOSE THE USER TO DANGER



REPORT ANY SERIOUS ACCIDENT INVOLVING THIS DEVICE TO THE MANUFACTURER AND TO THE COMPETENT NATIONAL AUTHORITY OF THE MEMBER STATE IN WHICH THE USER AND/OR PATIENT LIVES

The **BICARjet® S.r.l.** lines have been designed and built to ensure safe and efficient operation. Despite this, some anomalous conditions of use (for example non-compliance with the technical parameters required for the use of the machine and/or non-compliance with the enclosed instructions) can cause danger for the operator and the machine itself.

The user and/or operator must carefully prepare the most suitable environmental structures to ensure the highest general operational safety for the operator, the machine and the environment.

All the normal precautions dictated by the rules of good practice and common sense must necessarily be considered and applied to protect the users themselves.

The machine is equipped with a series of safety devices designed to ensure the safety of the operator and of the system itself.

For the protection of operators, the following are envisaged:

- 1) work cabin to isolate the spray area from the work environment;

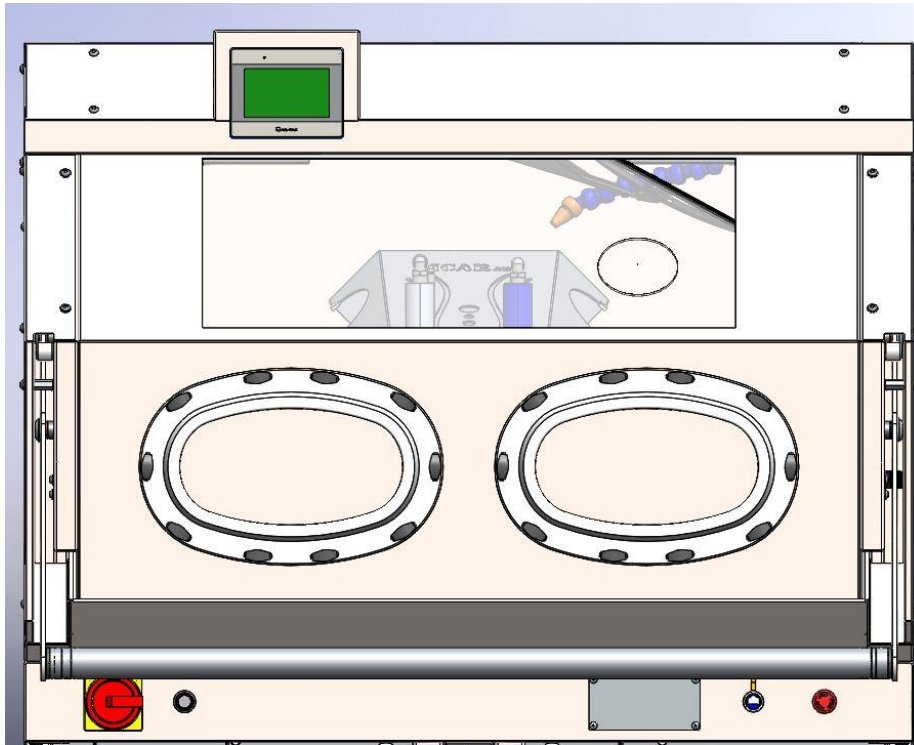

Fig. Work cabin

- 2) the mushroom-head emergency button on the front of the cabin immediately interrupts the work cycle.

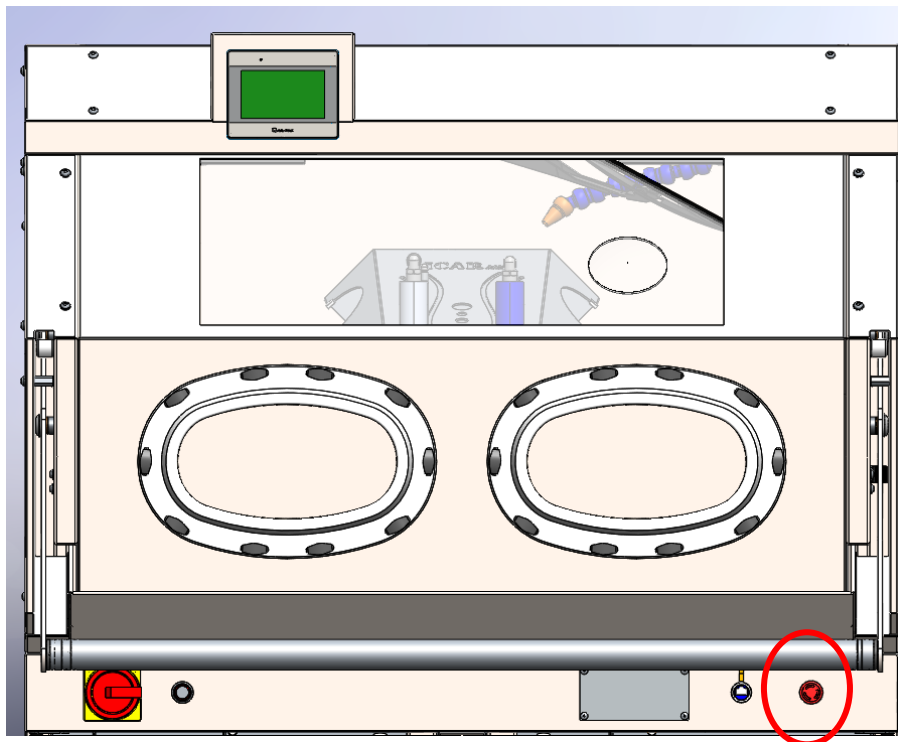

Fig. Emergency buttons

- 3) safety sensor which immediately interrupts the work cycle if the door at the front is opened.

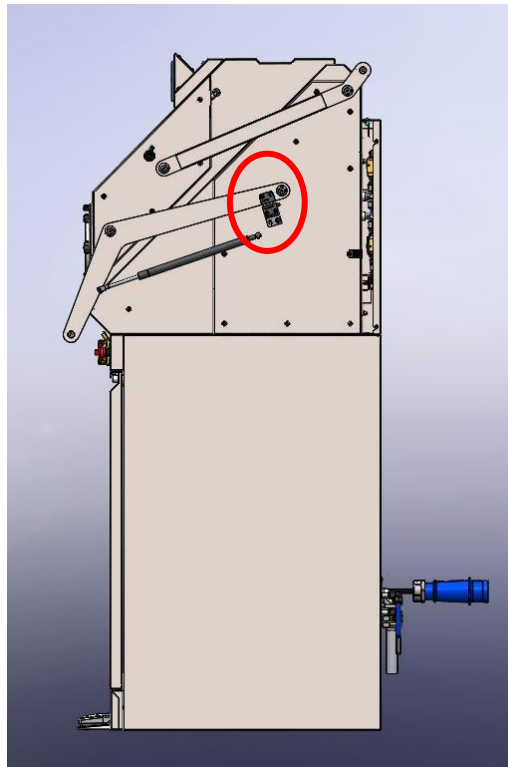

Fig. door sensor

- 4) the pedals that activate the functions of the device when pressed, but once released, instantly stop the spray in the cabin.

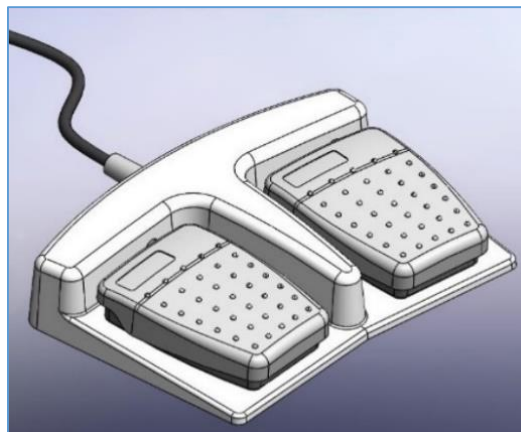

Fig. Pedal

5) Safety signs on the frontal door.



6) Safety signs on electrical cabinet.



7) Rear connections. AIR, WATER, EXHAUST and power supply.



1.9 COMPOSITION OF THE DEVICE



THE USE OF ITEMS THAT ARE NOT PART OF THE SYSTEM DESCRIBED ABOVE OR NOT SUPPLIED WITH THE DEVICE MAY JEOPARDIZE ITS SAFETY AND PERFORMANCE.



If not all the items listed have been received, contact the manufacturer immediately

The **SAFE CleanBox** device for cleaning metal surgical instruments manufactured by BICARjet® S.r.l. and hereinafter referred to simply as the **SAFE CleanBox**, integrates a number of elements including:

- A washing cabin
- **SAFEKLINIC®** Bicarbonate System
- Drainage system

The **SAFE CleanBox** is designed for the specific cleaning of various types of **metal surgical instruments** by means of a mixture of air and pressurized water enriched with abrasive particles consisting of **SAFEKLINIC®** synthetic sodium bicarbonate.

The **SAFE CleanBox** machine consists of a bicarbonate feed unit that uses pressurized air and water to supply a suitably mixed solution of **SAFEKLINIC®** synthetic sodium bicarbonate in suspension, via suction, for cleaning the instruments in the cabin.

This unit consists of a number of pneumatic components that allow the bicarbonate to be sprayed in an optimised and controlled manner.

The central element is the **SAFE CleanBox** washing cabin, which directs the flow of bicarbonate under pressure without contaminating the surrounding environment with bicarbonate dust and any residues that may have been removed. Through the assisted opening front door, this allows the insertion of trays containing the utensils to be cleaned. The cabin is equipped with a glass to allow the operator to control the

operations and by two full-arm and sealed gloves, to allow the operator to insert his hands from the outside to proceed with the operations necessary for cleaning tools. Inside there is a special handpiece from which the air-water-bicarbonate mixture under pressure comes out and a second handpiece from which a jet of pressurized water comes out to facilitate the cleaning operation and the removal of excess bicarbonate particles. The by-product obtained from cleaning, consisting of bicarbonate and removed residues, is collected in a sealed container placed under the cabin and directly aspirated. The third element of the line is the collection and discharge system for the collection and evacuation of dust and water mist present inside the cabin. Dust and mist are extracted from the cabin by the forced ventilation system and conveyed to this unit where the dust is slowed down and transferred to a collection container, and the air is filtered and expelled by the filter. Inside the collection container, the powders are mixed with water and are automatically expelled by means of an independent pump that conveys the processing residues directly into the sewage system.

The **SAFE CleanBox** machine is fitted with a control panel located in the lower compartment on the left of the machine. It is mounted on a series of guides for easier maintenance. The operating modes are controlled via a touch screen located above the cabin. The two handpieces are operated by a double pedal unit on the floor under the cabin. There is an emergency mushroom button placed outside the cabin.

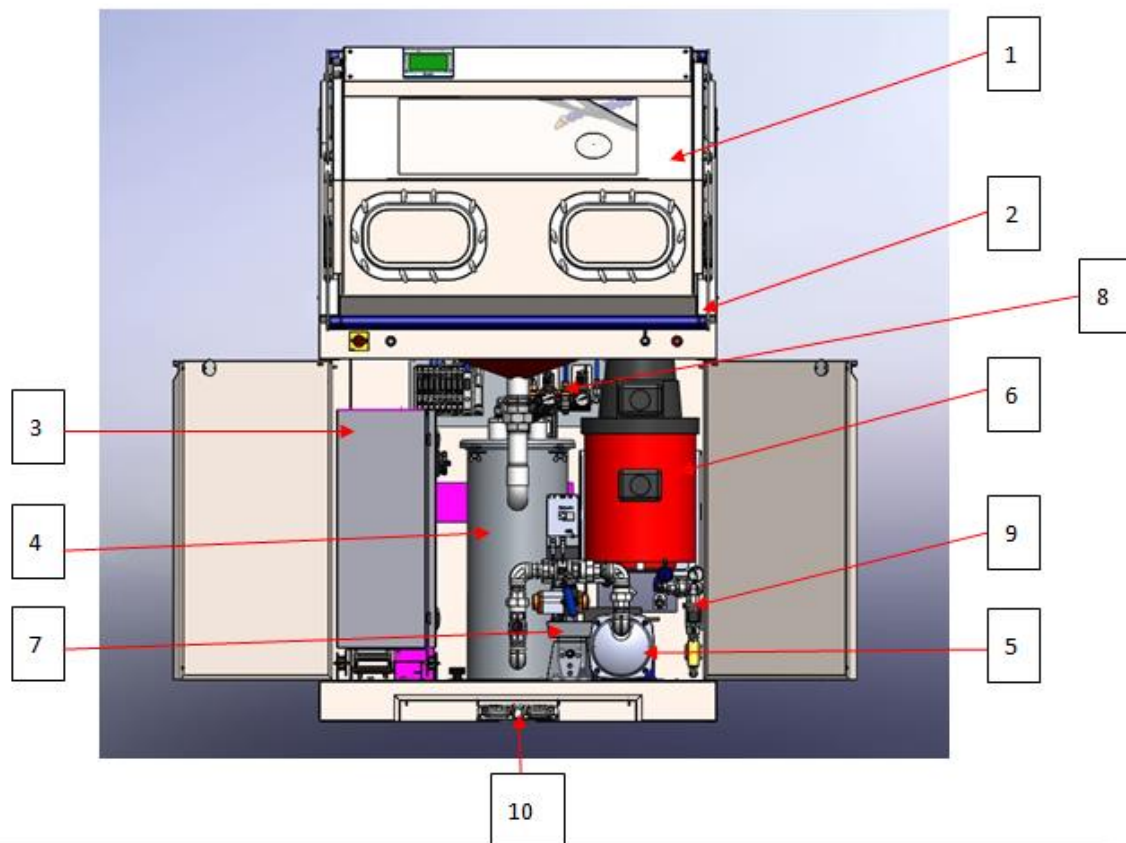

1	WASHING CABIN
2	FRONT DOOR OPENING HANDLE
3	ELECTRICAL PANEL
4	WASTE BIN
5	DRAIN PUMP
6	ASPIRATOR
7	SAFEKLINIC[®] FEED UNIT
8	AIR GROUP
9	WATER GROUP
10	PEDALS

SAFEKLINIC[®]

The inert product **SAFEKLINIC[®]** (bicarbonate) does not pose any danger to humans and the environment; it is advisable, however, to observe the following recommendations. During use and loading, unloading and cleaning of both the pieces to be cleaned and the aggregates and processing residues.



2 INSTALLATION



THE DEVICE MUST BE INSTALLED ONLY BY SPECIALIZED TECHNICAL PERSONNEL DULY TRAINED AND AUTHORIZED BY THE MANUFACTURER



DO NOT POSITION THE DEVICE IN SUCH A WAY THAT IT IS DIFFICULT TO UNPLUG FROM THE POWER SOCKET OR ACTIVATE THE CIRCUIT BREAKER



ENSURE THAT THE USE ENVIRONMENT MEETS THE REQUIREMENTS SET OUT IN THE “ELECTROMAGNETIC COMPATIBILITY” CHAPTER BELOW

Installation must be entrusted solely to qualified personnel:

those persons who have completed specialization courses, training courses, etc., and have experience in installing, commissioning and servicing, repairing and transporting machines produced by **BICARjet®**. A qualified technician, able to operate the system under normal conditions, to have it work with maintained action control with the guards deactivated, being assigned to all operations of an electrical nature to make adjustments and to perform maintenance and repairs. This technician can operate on live parts in electrical switchboards and junction boxes.

1) LAYING ON THE GROUND:

Place the machine on a flat and even surface according to the requirements at the workplace, to ensure correct horizontal positioning of the cabin.

2) CONNECTIONS:

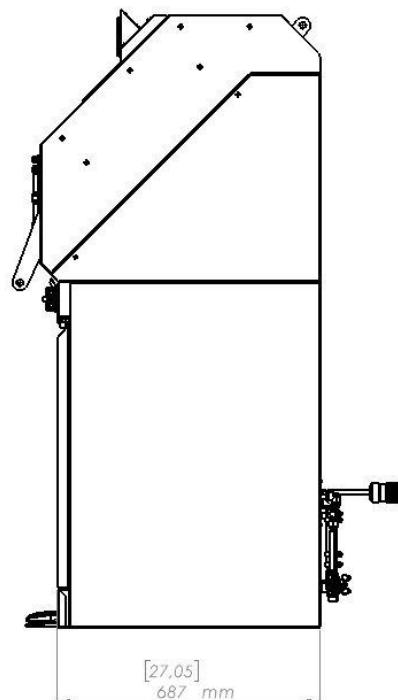
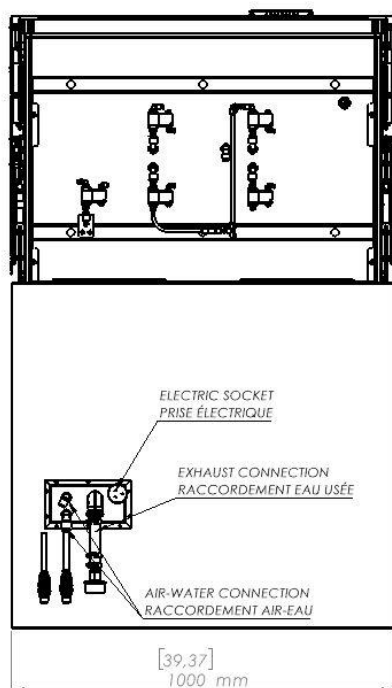

- **ELECTRICAL**

Connect the electrical socket to the **230 V 50 Hz 16 A** mains panel.

- **AIR**

Connect the compressed air delivery hose to the mains supply unit with quick coupling. DN 15 mm (1/2")

- **WATER**

Connect the water delivery hose to the mains supply unit with quick coupling. DN 15 mm (1/2")

- **DRAIN**

Connect the $\varnothing 40$ mm drain hose between the centrifugal pump and the drain line. It is essential to always ask the local health authorities for the current rules on drains at the place of use. The draining, retention and storage of part or all of the processing residues, whether liquid and/or solid, is at the complete care and responsibility of the user.

2.1 LIFTING AND TRANSPORT

The machine is packed inside a wooden crate.

Handling must be carried out with a forklift truck or transpallet.

Slings must NOT be used for lifting.



After opening the box, the machine must be lifted with special equipment designed for moving furniture.

If necessary, mini-skates can be used for moving in very confined spaces



It is possible to lift the SAFE CleanBox model STK 100 device through the use of a transpallet, removing the steel base from the front. If necessary, adjust the feet at the 4 bottom corners by opening the doors.

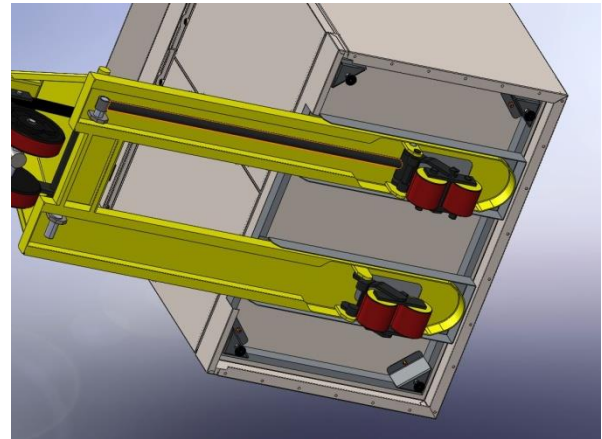
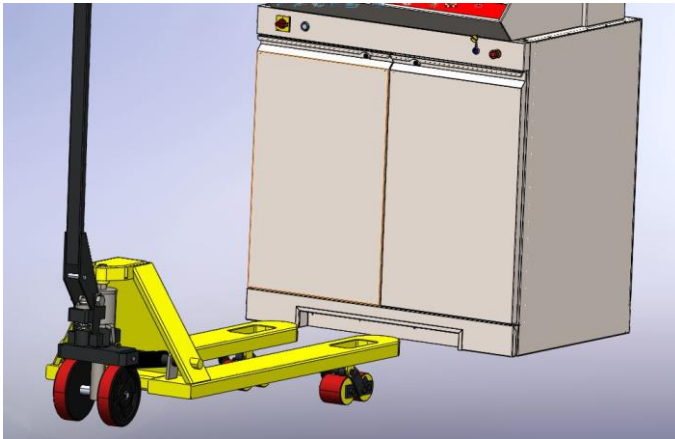

2.2 SET-UP OF USE ENVIRONMENT

The following operations are the responsibility of the **user**:

1. identification of the work area of the system and preparation before installation in such a way as to optimise the ergonomics and safety of the workplace. In particular, it is recommended to leave enough space around the work and passage areas to allow easy loading/unloading, maintenance and adjustment operations. Furthermore, the following general requirements should be taken into account when identifying the work area:
 - Place covered and protected from rain or bad weather.
 - Protection from splashes, humidity and direct sunlight.
 - Connected, smooth, flat and resistant floor.
 - Ambient temperature between +5 and +40°C.
 - Ambient relative humidity between 20 and 80%.
 - Well ventilated room.
 - Place away from electrical systems and free from objects that could be damaged, as well as free from other people.
 - When choosing the place of installation, consider the type of lighting; this must be diffused and not reflect off the glass of the window of the cabin, causing glare.
2. Any ducts for the passage of:
 - electrical cables;
 - hoses for the supply of compressed air;
 - any centralized drainage systems;
 - near the power supply unit and the electrical panel of the machine.
3. Wiring for the supply of electrical power and compressed air, up to the control panel and with power rating matching that on the data plate provided by **BICARjet® S.r.l.**, including earth connection.
 - Cordon off the work area to prevent unauthorized access.

2.3 PREPARATION FOR INSTALLATION

There must be sufficient space for manoeuvring the means of transport and for lifting of the device, in order to guarantee the safety of the operators entrusted with installation.

Wall predisposition simulation:

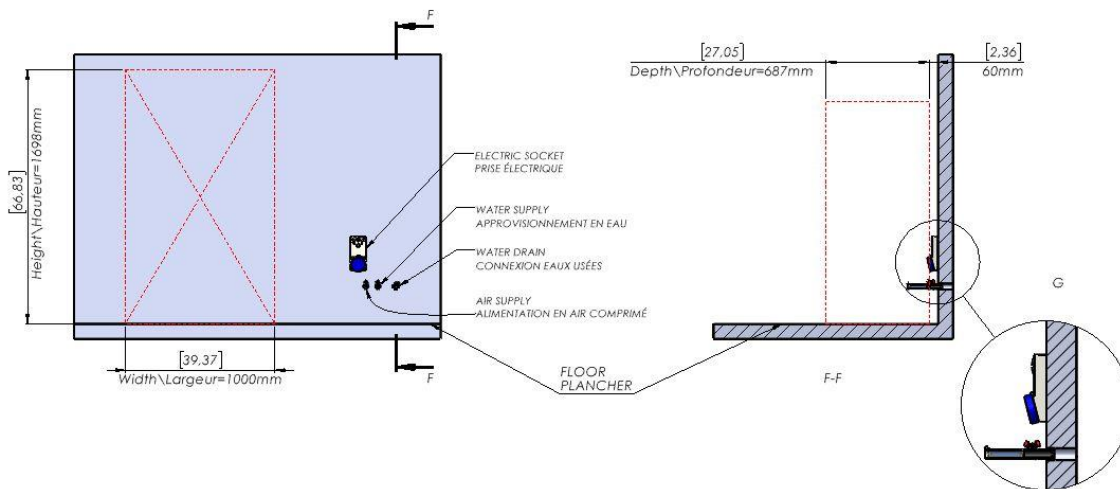

2.3.1 PREPARATION OF THE ELECTRICAL SYSTEM

The following are the responsibility of the **specialized technical staff**:

Electrical supply: **230 V 50 Hz 16 A**

Power: **3.2 kW**

The connection to the power supply network must be carried out by specialized and qualified personnel in accordance with the wiring diagram and the provisions of the Laws and/or Technical Standards in force pertaining to safety in the workplace and electrical systems. Appropriate safety devices must be provided for its operation in line with those required in the area of safety in the workplace.

To ensure a sufficient level of safety, please observe the general rules for the preparation and installation of electrical systems: the earthing system must meet the specific characteristics defined by the CEI 64-8 standard.

2.3.2 PREPARATION OF THE COMPRESSED AIR SYSTEM

Air supply: **6 (min) bar; max 10 bar**

Power line: **DN 15 mm (1/2")**

The supply air must be filtered to min. 50 microns, and must be dehydrated and free of dust and lubricating oils.

It should be possible to switch off the power supply socket by inserting a manual closing lever.

2.3.3 PREPARATION OF THE WATER SYSTEM

Water supply: **3 (min) bar**

Power line: DN 15 mm (1/2")

2.3.4 PREPARATION OF THE DRAINAGE SYSTEM

Connection to the non-hazardous industrial waste water discharge system according to *Annex V part III of Legislative Decree no. 152/06*

Wall drainage line: Ø40 mm

2.3.5 PREPARATION OF THE WORK AREA

In order to guarantee maximum safety, it is necessary to identify with horizontal signs the areas not to be accessed by exposed people, the loading and unloading areas, and the work area for the operator as indicated in the layout drawing.

2.4 POST-INSTALLATION CHECKS

NO-LOAD TESTS FOR INITIAL START-UP:

qualified personnel: those persons who have completed specialization courses, training courses, etc., and have experience in installing, commissioning and servicing, repairing and transporting the machine produced by BICARjet®. **Qualified technician:** the person responsible for all electrical adjustments, maintenance and repairs. This technician can operate on live parts in electrical switchboards and junction boxes.

CHECKS TO CARRY OUT ON MODEL STK 100				
No.	PRELIMINARY CHECKS	RESULT		
		Pos.	Neg.	N/A
	before supplying electrical power to the system, check:			
1	the integrity and stability of the system			
2	the integrity of the electrical, compressed air, water and drain connections			
3	that the air and water supply valves on the wall do not leak			
4	that the safety systems are intact and have not been triggered (emergency buttons)			
5	the integrity of the hoses in the cabin			
No.	OPERATION CHECKS	RESULT		
		Pos.	Neg.	N/A
	supply electrical power to the system and check:			
1	switching on of the touch panel and loading of the program			
2	switching on of the lights inside the cabin			
3	the absence of alarms/signals at the panel			
4	the presence of air/water at the panel			
5	operation of the emergency buttons			
6	operation of the door and the capacity of the gas springs to support it			
7	loading the SAFEKLINIC bottle			
8	operation of spray handpieces by pressing the pedals			
9	operation of the wiper/ wiper water by pressing the pedals			

10	absence of leaks			
11	operation of aspirator			
12	operation of drain pump			

MAINTENANCE REPORT				
SYSTEM STATUS/CONDITION				

ADJUSTMENTS:

The **STK100** machine delivered by **BICARjet® S.r.l.** is already set up and ready for operation.

Adjustments are only necessary during the service life when maintenance is carried out (see chapter 4: Maintenance).

It is recommended that these operations be carried out only by qualified personnel, or by the Manufacturer's personnel.

3 METHOD OF USE



CHECK THE INTEGRITY OF THE DEVICE BEFORE PROCEEDING WITH THE NEXT STEPS

3.1 SWITCHING ON THE DEVICE

SWITCHING ON:

- Make sure that the emergency buttons on the electrical panel are released.
- Visually check that the **SAFEKLINIC[®]** is present by opening the right door of the bench, load it if necessary.
- Turn on the main switch by turning clockwise the red selector at the bottom under the counter on the left wall of the central compartment.
- Visually check that the interior lights of the cabin are on.
- **RED BUTTON ON:** machine in lockout and alarm signal on the HMI panel
- Visually check through the glass that the working hoses of the guns inside the cabin are free and intact.
- Wait for the program to load completely, following the progress bar on the screen itself.
- The control and programming panel will light up on the home screen, confirming that it is ready to start the machine.

Any anomalies are shown on the HMI panel.

PERSONAL PROTECTIVE EQUIPMENT (PPE):
Nitrile gloves

3.2 START-UP AND OPERATION - LOGIN

In order to use the STK 100 device, you have to log in using the touch panel.

The STK 100 device is provided with 10 user accounts for enabling the machine, 9 for operators and 1 for a head of department. It is up to the employer to make sure that the pre-set user accounts are assigned to personnel specifically trained to use the machine.

The user accounts provided for the specifically trained personnel that use the machine have been given the following codes: **01, 02, 03, 04, 05, 06, 07, 08, 09**

The user account for the head of department, who is also specifically trained to use the machine, is as follows: **DEPARTMENT**

HOW TO LOG IN:



TO LOGIN, SEE THE USER AND PASSWORDS LIST - ANNEX 01 OF THIS MANUAL

<p>The operator must be logged in in order to use the machine; otherwise it will remain in a non-enabled condition.</p>	
<p>Selecting the KEY symbol will call up the login screen.</p>	
<p>Select the USER name on the monitor.</p>	
<p>Enter the PASSWORD on the monitor. (touching the empty field will call up the on-screen keyboard)</p> <p>Then press LOGIN</p>	
<p>The machine is now ready to operate.</p>	

HOW TO LOG OUT:

The device automatically logs out an operator after 5 minutes of inactivity of the machine.

To log out, press the highlighted icon on the monitor.	
	<p>19/01/22 WED 14:22:02 User: Reparto</p> <p>MACHINE IN STAND-BY</p> <p>WASHING RINSING</p> <p>Bicarbonate water flow 0 oz 0.00 gal/min Air presence</p>

3.2.1 CREATION OF NEW OPERATOR

CREATION OF NEW OPERATOR

This operation can be carried out only by a Head of Department.

Log in as a head of department.

Press the impostazioni (settings) icon.	
	<p>19/01/22 WED 14:22:02 User: Reparto</p> <p>MACHINE IN STAND-BY</p> <p>WASHING RINSING</p> <p>Bicarbonate water flow 0 oz 0.00 gal/min Air presence</p>
Press the User Management button.	
	<p>19/01/22 WED 11:17:03 User: Reparto</p> <p>PARAMETERS DIAGNOSTICS SYSTEM</p> <p>HISTORICAL ALARMS USERS COUNTERS LANGUAGE CHOICE</p> <p>PLC_STK1X0_V 0 _R 6 HMI_STK1X0_V 00 _R 06</p> <p>CLEANING CYCLE BICARBONATE UNLOCK INFLATION GLOVES</p>
Press the Add Users button	
	<p>19/01/22 WED 11:33:47 User: Reparto</p> <p>ADD</p>

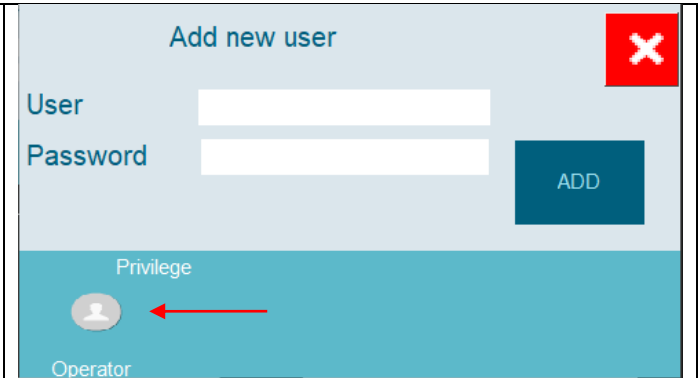
<p>Enter the number of the operator.</p> <p>Enter the password.</p> <p>Select the privilege level, which in this case will be "OPERATOR".</p> <p>Select OK.</p>	
<p>Creation of the new operator is completed.</p>	

3.2.2 OPERATION OF THE DEVICE:

IMPORTANT:

THE ITEMS TO BE PROCESSED ARE PLACED IN THE CABIN BY RAISING THE FRONT DOOR MANUALLY BY THE HANDLE.

The correct use of the SAFE Clean BOX requires the operator to initially insert an empty tray inside the cabin on which to place the treated material until all the dirty instruments have been cleaned.



The instructions for using the HMI panel are given in section 10 of this manual, where the different screens available and the functions that can be activated are shown.

3.2.3 OPENING THE CABIN

The operator should grip the handle below the gloves (detail in figure) with both hands and lift it upwards, guiding it until it is fully open.

Before closing the door, make sure that the gloves and hoses are not in the way. Close the door by pulling the handle downwards using both hands. Close the door as far as it will go and then push the handle firmly downwards to make sure that it is properly closed and sealed.

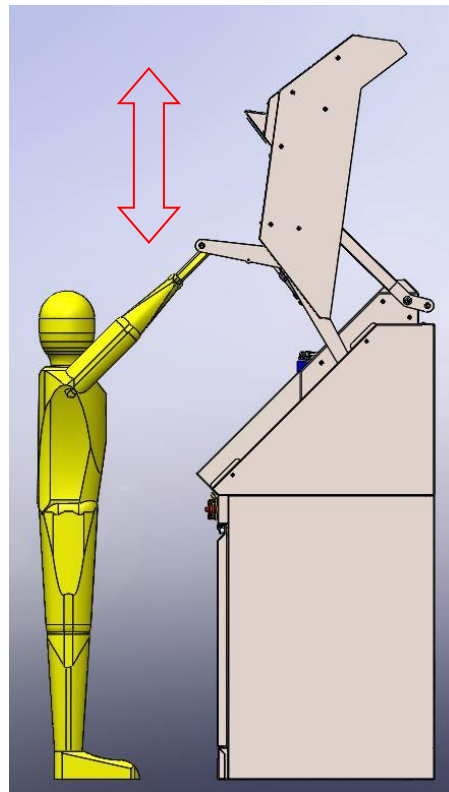
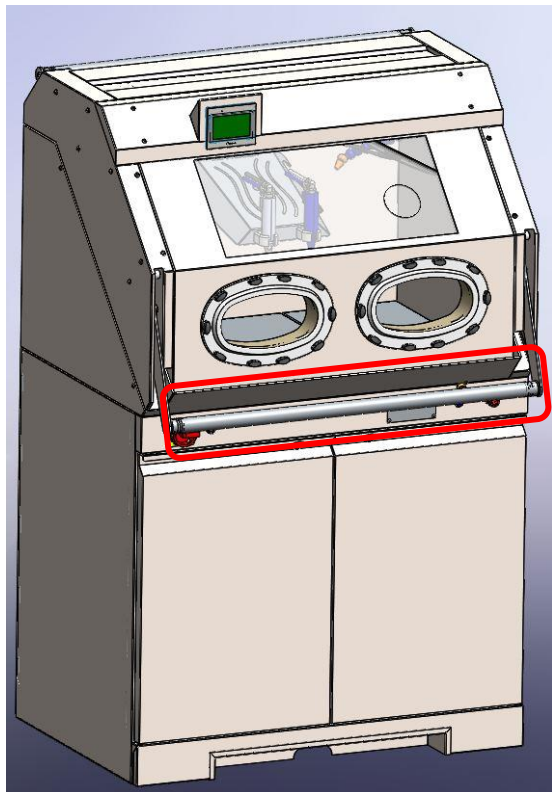

3.2.4 START CLEANING OF THE INSTRUMENTS

Put your hands in the special gloves. (you must already have put on protective gloves as indicated in the PPE table).

You can use the Air, Water and **SAFEKLINIC[®]** spray handpiece (grey with grey icon) fixed on its support or pulled out.

Firmly grip the instrument to be treated with both hands.

Press the left pedal to operate the white air, water and **SAFEKLINIC[®]** handpiece.

The "lavaggio" (washing) icon on the HMI panel turns orange to indicate that washing is enabled.

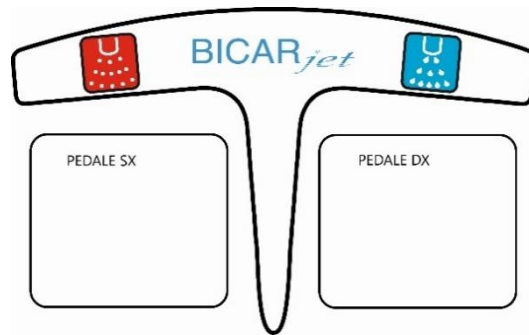

This function is activated only when the doors are closed.

Releasing the foot from the pedal, the washing function will stop automatically, interrupting the jet from the handpiece.

When the pedal is released, the lights on the push-button panel start flashing again. This means that the device is ready for a new function or to repeat the previous one.

FOLLOW THE PROCEDURE BELOW FOR TREATING THE INSTRUMENTS IN ORDER TO ENSURE CORRECT USE OF THE SAFE CLEAN BOX AND SATISFACTORY CLEANING.

3.2.5 INSTRUMENT TREATMENT PROCEDURE

Keep a minimum distance of 5 to 10 cm between the spray nozzle and the instrument to be treated.

Cover all surfaces of the instrument to be treated with the jet of **SAFEKLINIC[®]**.

Smooth and flat surfaces can be simply passed in a gradual manner under the jet of **SAFEKLINIC[®]**.

Hold pivot points and joints under the jet of **SAFEKLINIC[®]** for at least 10 seconds and turn the instrument to allow the jet to cover the entire surface.

IMPORTANT:

WE RECOMMEND USING THE MAGNIFYING GLASS ON THE GLASS PANEL TO INSPECT THE INSTRUMENT THAT HAS JUST BEEN TREATED, IN ORDER TO INSTANTLY IDENTIFY ANY REMAINING TRACES OF DIRT.

IMPORTANT:

RINSE ALL THE TREATED INSTRUMENTS (USING THE BLUE HANDPIECE), BOTH INSIDE THE CABIN AND ONCE THEY ARE TAKEN OUT.

3.2.6 INSTRUMENT RINSING PROCEDURE

Each instrument treated with **SAFEKLINIC[®]** requires a rinse to eliminate any residual product.

You can use the blue air and water spray handpiece fixed on its support or pulled out.

Firmly hold the instrument that has been treated with both hands.

Press the right pedal to operate the blue air and water handpiece.

The "risciacquo" (rinsing) icon on the HMI panel turns orange to indicate that rinsing is enabled.

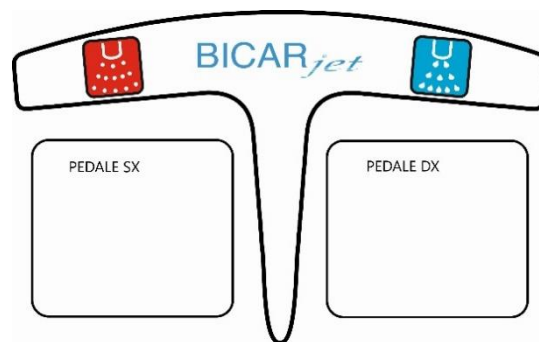

The RISCIAQUO (rinsing) function can be activated only with the doors closed by pressing the right pedal.

Releasing the foot from the pedal, the washing function will stop automatically, interrupting the jet from the handpiece.

When the pedal is released, the lights on the push-button panel start flashing again. This means that the device is ready for a new function or to repeat the previous one.

3.2.7 INSTRUMENT BLOWING PROCEDURE

It is possible to blow compressed air on the treated instruments by closing the water tap located above the blue handpiece.



DURING CLEANING AND RINSING OPERATIONS, HANDLE THE INSTRUMENTS TO BE TREATED WITH CARE, ESPECIALLY IF THEY ARE POINTED OR SHARP.

IMPORTANT:

BEFORE PROCEEDING WITH SANITIZATION OF THE CABIN, CHECK OPENING OF THE WATER TAP LOCATED ABOVE THE BLUE HANDPIECE, OTHERWISE THE DEVICE WILL SIGNAL AN ERROR.

3.2.8 MATERIALS COMPATIBLE WITH THE TREATMENT

STAINLESS STEEL	COMPATIBLE
TITANIUM	COMPATIBLE
TUNGSTEN	COMPATIBLE
CERAMICS	COMPATIBLE
GLASS	COMPATIBLE
CANNULATED INSTRUMENTS	COMPATIBLE
MICROSURGERY	COMPATIBLE
RIGID OPTICS	COMPATIBLE only on LENS and STEM
MOTORS	NO DIRECT EXPOSURE ON ELECTRICAL PARTS
ELASTOMERS	NO PROLONGED EXPOSURE
POLYMERS	NO DIRECT EXPOSURE
PAINTED MATERIALS	NOT COMPATIBLE

ALUMINIUM	NOT COMPATIBLE
RESINS	NOT COMPATIBLE
ELECTRICAL WIRES	NOT COMPATIBLE
BATTERY HOLDER	NOT COMPATIBLE

3.3 END

IMPORTANT:

THE INSTRUCTIONS IN THE TABLES OF CHAPTER 4.1 - ROUTINE MAINTENANCE - MUST BE FOLLOWED TO ENSURE CLEANING OF THE SYSTEM IN SAFETY.

SWITCHING OFF

- It is mandatory to turn off the main switch of the **SAFE CleanBox** by moving it to the horizontal **0-OFF** position.

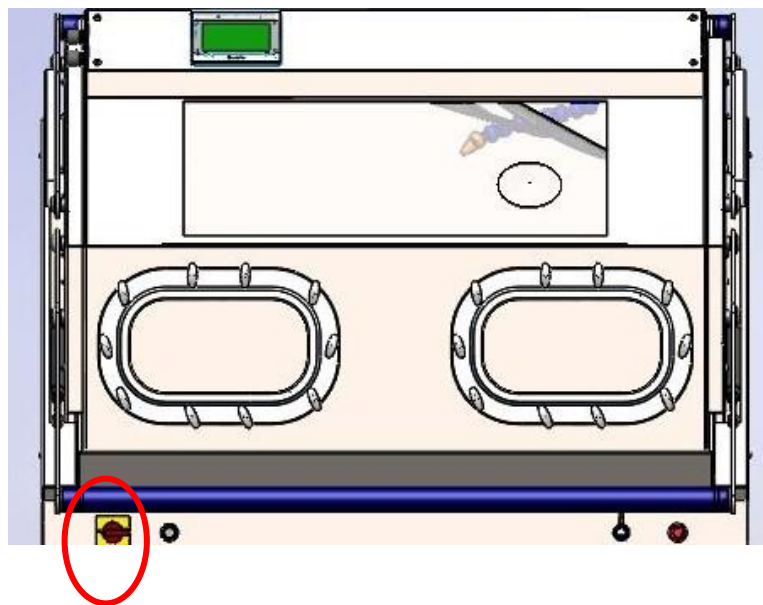

EMERGENCY STOP

- Each operation can be stopped by pressing one of the two emergency buttons on the **SAFE CleanBox**.

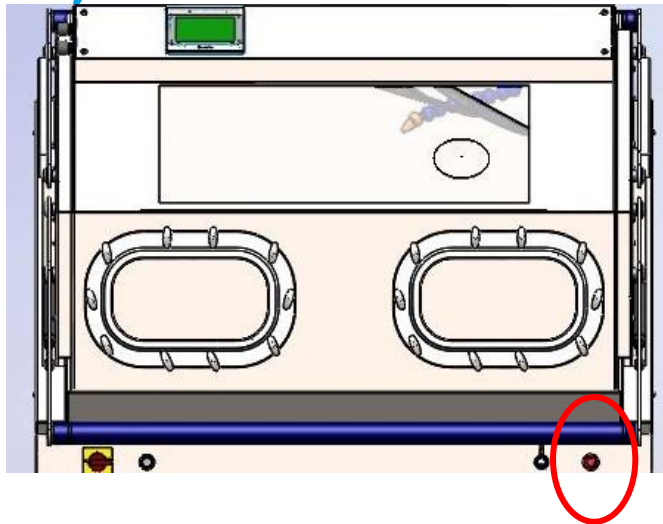

Fig. Mushroom-head emergency stop buttons

The device can be stopped in an emergency by pressing the "Emergency" stop button on the front of the cabin, which stops the machine immediately and disconnects power to the panel.

STANDBY

- The standby function is activated automatically after 5 minutes of inactivity. The lights of the machine will turn off but the aspirator will always be ready for use whenever an operator presses a button or the pedals.

3.4 NOTIFICATIONS / ALARMS

ALARM MESSAGES		
No. - MESSAGE	TYPE OF DISENGAGEMENT	TYPE OF ALARM
01-EMERGENCY ON	RESET	MAJOR
02-DOORS OPEN	AUTORESET	MAJOR
03-DRAIN WATER PUMP THERMAL	RESET	MAJOR
04-INSUFFICIENT AIR PRESSURE	RESET	MAJOR
05-INSUFFICIENT WATER	RESET	MAJOR
06-BICARBONATE CARTRIDGE NOT LOADED	RESET	MAJOR - MINOR
07-LOW BICARBONATE LEVEL	AUTORESET	MINOR
08-INSUFFICIENT BICARBONATE LEVEL	RESET	MAJOR
09-INCONSISTENT BICARBONATE LEVEL	RESET	MAJOR
10-RFID BOTTLE CODE NOT RECOGNIZED	RESET	MAJOR
11-ASPIRATOR THERMAL	RESET	MAJOR
12-PNEUMATIC UNIT ALARM	RESET	MAJOR
13-MAXIMUM LEVEL OF DRAIN WATER	AUTORESET	MAJOR - MINOR
14-WEIGHING DEVICE ERROR	RESET	MAJOR
15-RFID TAG READER ERROR	RESET	MAJOR
16-		
17-		
18-WATER LEVEL SENSOR	RESET	MAJOR
19-WATER DRAINAGE	AUTORESET	MINOR
20-		
21-		
22-COMMUNICATION WITH WEIGHING DEV.	RESET	MAJOR
23-COMMUNICATION WITH RFID TAG READER	RESET	MAJOR
24-WEIGHING CELL ERROR	RESET	MAJOR
25-		
26-MAXIMUM TIME FOR FILLING THE BIN	RESET	MAJOR
50-DOOR NOT CLOSED DURING CYCLE	RESET	MAJOR
55-		
56-		

57-BOTTLE RFID ERROR	RESET	MAJOR
58-		
59-		
60-BICARBONATE BLOCKED	RESET	MAJOR
61-MEDIUM LOW BICARBONATE FLOW	RESET	MINOR
62-LOG CREATION ERROR	RESET	MAJOR
63-LOG WRITING ERROR	RESET	MAJOR
64-LOG OPENING ERROR	RESET	MAJOR
65-PROFINET COMMUNICATION ERROR BOTTLE RFID	AUTORESET	MAJOR

3.4.1 ALARM GUIDE

01-EMERGENCY ON	Reset the emergency button by turning it and reset any messages.
02-DOORS OPEN	Close the door.
03-DRAIN WATER PUMP THERMAL	Contact assistance
04-INSUFFICIENT AIR PRESSURE	Insufficient air supply - reset
05-INSUFFICIENT WATER	Insufficient water supply - reset
06-BICARBONATE CARTRIDGE NOT LOADED	Reset
07-LOW BICARBONATE LEVEL	Indicates that the bicarbonate is down to the reserve level and the bottle will need to be replaced soon
08-INSUFFICIENT BICARBONATE LEVEL	The bicarbonate has run out. Replace the bottle and press "cambio bottiglia" (change bottle) on the touch panel.
09-INCONSISTENT BICARBONATE LEVEL	The bicarbonate bottle has been tampered with, replace it.
10-RFID BOTTLE CODE NOT RECOGNIZED	Replace the bottle
11-ASPIRATOR THERMAL	Contact assistance
12-PNEUMATIC UNIT ALARM	Contact assistance
13-MAXIMUM LEVEL OF DRAIN WATER	Contact assistance
14-WEIGHING DEVICE ERROR	Reset
15-RFID TAG READER ERROR	Reset
18-WATER LEVEL SENSOR	Contact assistance
19-WATER DRAINAGE	The discharge pump is draining the collection bin. autoreset

22-COMMUNICATION WITH WEIGHING DEV.	autoreset
23-COMMUNICATION WITH RFID TAG READER	Reset
24-WEIGHING CELL ERROR	Reset
25-	
26-MAXIMUM TIME FOR FILLING THE BIN	Reset
50-DOOR NOT CLOSED DURING CYCLE	Close the door and continue.
55-OPENING-CLOSING DOOR TIMEOUT	Reset and, if it persists, contact assistance.
57-BOTTLE RFID ERROR	Reset, if the problem persists, replace the bottle or contact assistance
60-BICARBONATE BLOCKED	Follow the instructions in the monthly maintenance schedule then press Reset. If the problem persists, contact assistance
61-MEDIUM LOW BICARBONATE FLOW	Reset
62-LOG CREATION ERROR	Memory full
63-LOG WRITING ERROR	Reset if it persists, contact support
64-LOG OPENING ERROR	Reset if it persists, contact support
65-USER NOT RECOGNIZED	Unknown user error

3.5 REPLACEMENT OF CONSUMABLES

BICARBONATE REPLACEMENT PROCEDURE:

Open the lower doors.

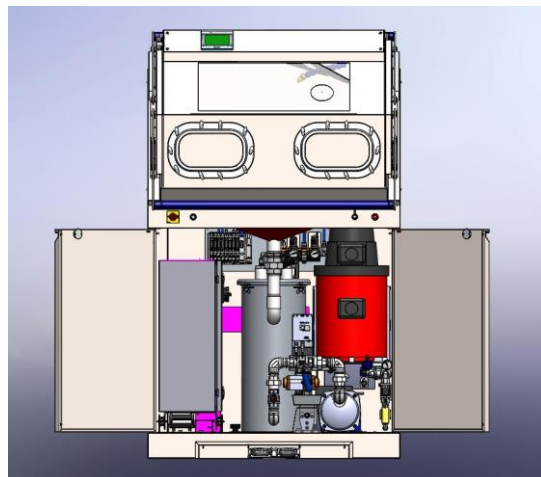

Close the bottle outlet valve (1) by turning it 90 degrees.

Before lifting the bottle (2), rotate the support bracket of the RFID reader (3) upwards.

Then lift the bottle by gripping it by the valve.

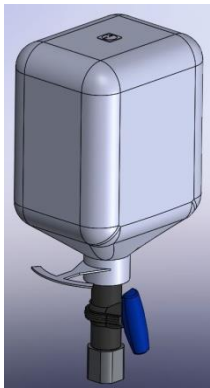

BOTTLE UNIT

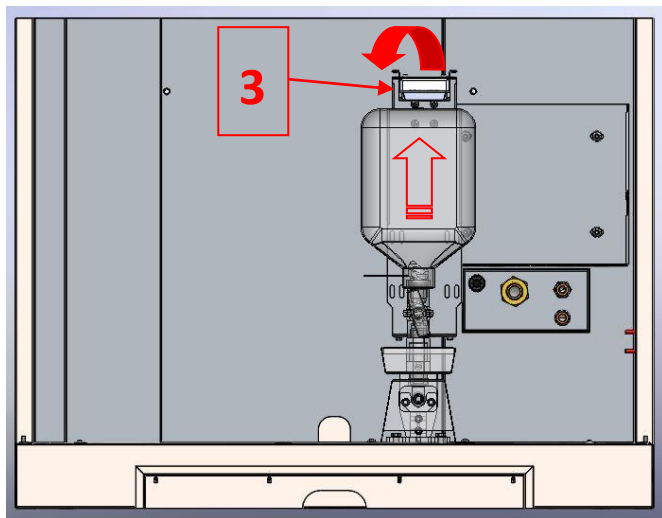
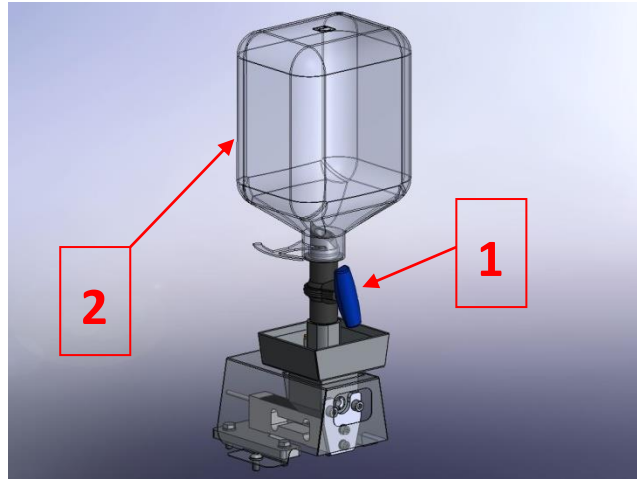

After having removed the bottle unit, remove the valve unit from the empty bottle and insert it into a new one.

Turn the bottle upside down and place it on its support.

Open the bicarbonate outlet valve by turning it 90 degrees.

Check the correct vertical positioning of the bottle and the presence of the tag on the bottom.

Tilt the RFID reader support bracket downwards.

Check that the orange light of the reading sensor switches on.

Check that the weight of the new bottle (about 6000 g) has been read correctly in the field at the bottom right on the HMI panel.

Press the left pedal and check that the SAFEKLINIC comes out of the grey handpiece and that there are no alarm messages.

IN CASE OF ANOMALY, REPLACE THE SAFEKLINIC BOTTLE.

4 MAINTENANCE

The purposes of maintenance are:

- To keep the device in good working order and ensure maximum production at the best quality, minimizing residual risks associated with use of the system;
- to prevent failures and breakages and guarantee repairs in the shortest possible time;
- to increase the efficiency of the machines and avoid overly expensive breakdowns and repairs.

The need to carry out this work is established by conducting routine checks and inspections, which simply involve measurements and physical tests to determine the conditions of the machine and main equipment most prone to wear.

The personnel is required to observe the system on the basis of the following sensory principles:

- sight, i.e. optical and visual observation;
- hearing, i.e. listening for noises;
- touch, i.e. sensory detection of temperature, vibrations etc.

These checks, inspections, adjustments or replacements must be carried out at the frequency indicated in the **PREVENTIVE MAINTENANCE SCHEDULE** prepared by the manufacturer.

The work involves routine maintenance as well as non-routine maintenance following faults or breakages.

The management of maintenance has been divided into:

- ROUTINE MAINTENANCE – daily, weekly and monthly
- PREVENTIVE MAINTENANCE - every 4 months
- NON-ROUTINE MAINTENANCE/FAULTS - at the request of the customer or on the manufacturer's recommendation



The useful life of the device if used and maintained properly is 10 years

4.1 ROUTINE MAINTENANCE

ROUTINE MAINTENANCE consists of daily and monthly inspections and checks aimed at obtaining the maximum operating efficiency of the machine.

Routine maintenance is divided into daily and monthly inspections/checks.

Only the prescribed materials (**SAFEKLINIC[®]** and **BICARjet[®] Original Spare Parts**) must be used and routine maintenance must be carried out in a regular and systematic manner in accordance with the indications given in the specific work schedule below.

Trained operators who use the machine and carry out routine daily maintenance must follow the instructions below:

PERSONAL PROTECTIVE EQUIPMENT (PPE):
Nitrile gloves
Protective glasses or face shields
Body gowns or coveralls
Protective footwear

The manufacturer BICARjet S.r.l. is not liable for injury or damage due to non-compliance with this provision.

In turn, the employer should evaluate the risks for the operators deriving from the routine maintenance, cleaning and sanitization of the system, in order to define the PPE that it deems most appropriate to carry out these activities and to inform the personnel.

ROUTINE MAINTENANCE: DAILY		
CHECKS AT THE START OF THE WORK SCHEDULE		
DESCRIPTION	WHO	ACTIONS
LEVEL OF SAFEKLINIC[®] BICARBONATE	TRAINED OPERATOR	Visually check the quantity of SAFEKLINIC [®] bicarbonate in the bottle located in the lower right compartment. The weight and level of the bottle are indicated on the HMI panel. If necessary, replace the bottle by extracting the whole unit, closing the valve and sliding the bottle upwards. Then insert the valve into the new container, turn the bottle upside down and place it in the appropriate space in the feed unit.
INSIDE LIGHTS	TRAINED OPERATOR	Visually check that the inside lights of the cabin switch on and that the LEDs of the internal push-button panel start flashing (green light, blue light and blue button)
GLOVES AND FLANGES	TRAINED OPERATOR	To avoid unnecessary accidents, it is recommended to visually check the state of wear of the gloves at the beginning of each work cycle, immediately reporting to the internal maintenance manager the presence of any abnormal cuts or abrasions that could affect tactile sensitivity and safe use of the same. It is also important to check closing of the glove flanges on the front of the panel to avoid leaks.
NOZZLES	TRAINED OPERATOR	Before starting the work schedule, check by sight the proper functioning of the spray nozzles by checking that

		<p>the mixture of air, water and SAFEKLINIC[®] flows freely and continuously from the grey handpiece, responding to the command of the left pedal, according to your practice and that the air and water mixture flows freely from the blue handpiece, responding to the command of the right pedal. In relation to the functions described, visually check the operation of the wiper.</p> <p>DO NOT OBSTRUCT OR PLUG THE NOZZLE OUTLET!</p>
SEALS	TRAINED OPERATOR	<p>It is advisable to check visually and by touch (if possible) the air-tightness and wear of the cabin seals. (example: glass panel and door).</p>

ACTIVITIES AT END OF WORK SCHEDULE		
DESCRIPTION	WHO	ACTIONS
RINSING INSIDE THE CABIN	TRAINED OPERATOR	<p>After using the machine, all processing residues containing SAFEKLINIC[®] inside the cabin must be rinsed out (with the doors closed) through the blue handpiece. This must be done because the bicarbonate is hygroscopic and highly sensitive to the external environment, and humidity can cause the crystallization of the grains of bicarbonate in the conduits inside the cabin, obstructing them and compromising their durability.</p> <p>Visually check and make sure to also clean the area under the gloves and the entire surface of the ceiling of the cabin with the jet of water.</p>
SANITIZATION OF THE CABIN	TRAINED OPERATOR	<p>SANITIZATION is, to all intents and purposes, a form of machine maintenance that aims to minimize, as far as possible, the risks of the stagnation and spreading of processing residues that could affect the safety of users. For this reason, sanitization is to be considered part of the MANDATORY daily maintenance before shutdown. After rinsing, as described above, carry out the sanitization procedure.</p> <p>Place a decontaminating spray in the cabin and close the door.</p> <p>Spray the entire inner surface of the cabin, paying particular attention to the less visible parts such as the area under the gloves, the roof, the gloves, below the bracket of the</p>

		<p>handpieces and spray everything with the sanitizing solution.</p> <p>Leave it for the contact time indicated by the manufacturer of the product.</p> <p>Rinse the entire inner surface of the cabin using the blue handpiece.</p>
<p>CLEANING AND SANITIZATION OF THE EXTERNAL PARTS OF THE CABIN</p>	<p>TRAINED OPERATOR</p>	<p>Open the front door and thoroughly rinse the outer closing edge of the door with a cloth dampened with water and sanitize the parts using a sanitizing spray.</p> <p>Leave it for the contact time indicated by the manufacturer of the product.</p> <p>Rinse the parts with a cloth dampened with water.</p> <p>Carry out the same procedure for the external surfaces of the cabin and see chapter 4.3.</p>

ROUTINE MAINTENANCE: WEEKLY

ACTIVITIES AT END OF WORK SCHEDULE

DESCRIPTION	WHO	ACTIONS
<p>CLEANING IN CABIN WITH BICARBONATE</p>	<p>TRAINED OPERATOR</p>	<p>Clean the internal walls of the cabin thoroughly using the bicarbonate handpiece. This will permit complete mechanical removal of all solid residues deposited inside.</p> <p>Visually check that all residues have been removed, using the blue handpiece to rinse thoroughly with pressurized water.</p>
<p>SANITIZATION OF THE CABIN</p>	<p>TRAINED OPERATOR</p>	<p>Sanitize the inside of the cabin as indicated at the end of work activities in the previous table.</p>
<p>SANITIZATION OF THE SUPPORT SURFACES INSIDE THE CABIN</p>	<p>TRAINED OPERATOR</p>	<p>Remove each support surface (3 surfaces) from the cabin by lifting them upwards. Leave them to soak in a tank containing a solution of water and disinfectant.</p> <p>Wait for the contact time declared by the product.</p> <p>The support surfaces inside the cabin can be cleaned using standard thermal disinfection wash cycle.</p>

		Visually check that the tank under the support surfaces and the drain are free from solid residues, otherwise use the blue handpiece to rinse them until the material has been completely removed.
SANITIZATION OF THE GLOVES	TRAINED OPERATOR	Remove the gloves by taking off the front flanges and leave them to soak in a tank containing a solution of water and disinfectant for 10 minutes.
CLEANING THE INSIDE OF THE GLASS PANEL	TRAINED OPERATOR	Introduce an anti-limescale spray in the cabin, cover all the glass internally, wait 2 minutes and rinse thoroughly using the blue handpiece.

ROUTINE MAINTENANCE: MONTHLY		
ACTIVITIES AT END OF WORK SCHEDULE		
DESCRIPTION	WHO	ACTIONS
CLEANING THE BICARBONATE FEED UNIT	TRAINED OPERATOR	<p>Remove the bottle of SAFEKLINIC, closing the valve manually. Completely remove any excess bicarbonate that has accumulated in the injection port using the suction system. Replace the bottle of SAFEKLINIC with the valve closed.</p> <p>Now run the automatic cleaning cycle for the bicarbonate feed unit using the "UNBLOCK BICARBONATE" function on the settings/menu screen.</p> <p>Once the cycle has been completed, open the valve of the SAFEKLINIC bottle. Press the spray pedal and make sure that the weight of bicarbonate decreases.</p>
BIN CLEANING	TRAINED OPERATOR	<p>Press settings on the HMI touch panel and then press the CLEAN BIN button.</p> <p>The button will become blue (in operation) and will activate a cycle in which water jets will automatically clean the inside of the collection bin and then discharge the contents via the pump. All operations are repeated twice.</p> <p>The duration of the cycle varies from 3 to 5 minutes.</p>

IMPORTANT:

Any damage due to wear, breakages or malfunctions encountered during the inspections/checks described above must be reported to the department manager and to the manufacturer (BICARjet S.r.l.). The customer, and therefore the trained operators who use the **SAFE CleanBox** machine, are only authorized to replace the gloves.

4.2 PREVENTIVE MAINTENANCE

PREVENTIVE MAINTENANCE means all the maintenance operations of inspection/control, adjustment and replacement of parts aimed at preventing breakdown, according to established criteria.

To be carried out by:

BICARjet® S.r.l. technician qualified technician provided by **BICARjet® S.r.l.** or specialized personnel trained by **BICARjet® S.r.l.** to carry out replacements / repairs and operational checks.

Frequency:

every four months.

An indicator light on the HMI touch panel of the SAFE CleanBox devices indicates if scheduled preventive maintenance has to be carried out:



CHECKS TO CARRY OUT ON MODEL STK 100				
No.	PRE-MAINTENANCE ACTIVITIES	RESULT		
		Pos	Neg	N/A
1	Visually inspect the integrity and stability of the system			
2	Sanitization of the inside of the cabin			
3	Sanitization of the outside of the cabin			
4	Sanitization of the mats inside the cabin and the gloves			
No.	OPERATIONS	RESULT		
		Pos	Neg	N/A
1	General cleaning of the system			
2	Check the integrity and operation of the safety devices			
3	Check the integrity of the glass and the tightness of the seal			
4	Check the integrity and operation of the LED lamps			
5	Check the integrity and operation of the door at the front and the seal			

6	Check the integrity and the seal of the glove flanges and gloves			
8	Check the integrity of the hoses inside the cabin			
9	Check the integrity of the pedals, their connector and the operation of the handpieces inside the cabin			
10	Check the operation of the external touch panel			
11	opening of the bench doors			
11	Check the integrity and operation of the aspirator			
12	Check the integrity of the air/water/drain hoses, the air pressure gauges and the reading of the water flow switch			
13	Check the integrity of the collection bin under the bench			
14	Opening of the collection bin, sanitization of the lid and bin			
15	Cleaning of the bicarbonate compartment under the bench			
16	Check the integrity and operation of the bicarbonate feed unit			

MAINTENANCE REPORT				
SYSTEM STATUS/CONDITION				

4.3 NON-ROUTINE MAINTENANCE AND REPAIRS

NON-ROUTINE MAINTENANCE AND REPAIRS means all diagnostics, replacement and adjustment of parts, aimed at repairing a fault or resolving anomalies, according to established criteria.

To be carried out by:

BICARjet® S.r.l. technician qualified technician provided by **BICARjet® S.r.l.** or specialized personnel trained by **BICARjet® S.r.l.** to carry out replacements / repairs and operational checks.

DIAGNOSTICS AND TROUBLESHOOTING:

- **The device does not start:**
 Check that the emergency mushroom-shaped buttons on the cabin are not pressed, and if necessary release the buttons by turning them anticlockwise and repeating the start-up procedure.
- **Air or water alarm:**
 Check the pressure and flow rate of the compressed air and/or water supply, which is too low. Check that the supply valve is completely open and check the inlet piping for any bottlenecks.
- **The electrical equipment does not work:**
 Check the electrical connection and, if the problem is not solved, check the fuses located inside the electrical panel.
- **Generic alarm does not reset:**

first activate the emergency buttons and then rearm them, reset everything and see if the problem has been resolved, or turn the system off and on again.

- **Bicarbonate blocked or inconsistent:**
follow the monthly maintenance procedure to unblock the bicarbonate, if blocked.
If inconsistent, replace the bottle.
- **When operating the wiper, the blade does not move:**
Check that the fixing screw of the arm has not come loose. If necessary, re-tighten the screw and make sure it is symmetrical in relation to the axis of the wiper itself.

4.4 POST-MAINTENANCE CHECKS

CHECKS TO CARRY OUT ON MODEL STK 100				
No.	PRELIMINARY CHECKS	RESULT		
	before supplying electrical power to the system, check:	Pos.	Neg.	N/A
1	the integrity and stability of the system			
2	the integrity of the electrical, compressed air, water and drain connections			
3	that the air and water supply valves on the wall do not leak			
4	the safety systems are intact and have not been triggered			
5	the integrity of the hoses in the cabin			
No.	OPERATION CHECKS	RESULT		
	supply electrical power to the system and check:	Pos.	Neg.	N/A
1	switching on of the touch panel and loading of the program			
2	switching on of the lights inside the cabin			
3	the absence of alarms/signals at the panel			
4	the presence of air/water at the panel			
5	operation of the emergency buttons			
6	operation of the door and the capacity of the gas springs to support it			
7	loading the SAFEKLINIC bottle			
8	operation of spray handpieces by pressing the pedals			
9	operation of the wiper/ wiper water by pressing the pedals			
10	absence of leaks			
11	operation of aspirator			
12	operation of drain pump			

4.5 TECHNICAL ASSISTANCE

BICARjet S.r.l.

Registered office - Via Nona Strada, 2 - 35129 Padova, Italy

Tel. 049 7808036 / fax. 049 7927203

info@bicarmed.com

4.6 WARRANTY TERMS AND CONDITIONS

The terms and conditions of the warranty are:

- validity for 12 months from the date of testing and commissioning of the machine

(materials recognized by the manufacturer as defective, excluding consumables and normal wear and tear)

5 CLEANING

In addition to cleaning the interior of the cabin, which should always be carried out after use of the device according to the instructions given previously, it is also important to keep the external surfaces of the device clean.

Clean the casing of the device, the panels and the controls with soft cloths that are dry or that have been dampened with a mild detergent solution. **Do not use any type of solvent, such as alcohol or petrol, as they may damage the surfaces. Do not use substances that are abrasive or corrosive or contain chlorine.** This operation must be done at least once a week.

NOTICE:

THE INSTRUCTIONS IN THE TABLES OF CHAPTER 4.1 - ROUTINE MAINTENANCE - MUST BE FOLLOWED TO ENSURE CLEANING OF THE SYSTEM IN SAFETY.

6 DISPOSAL



Do not dispose of this product and its accessories as unseparated waste. Prepare the product for recycling or separate collection in accordance with Italian Legislative Decree no. 49 of 14 March 2014 entitled "Implementation of Directive 2012/19/EU, on waste electrical and electronic equipment (WEEE)".

When used in hospitals, follow their internal rules for the disposal of electrical and electronic waste.

7 TECHNICAL FEATURES

Model	SAFE CLEAN BOX
Code	STK100
Dimensions	1000 mm (w) x 687 mm (d) x 1697.5 mm (h)
Weight	320 kg
Power supply	220 V - 50 Hz - 16 A
Power consumption	3.2 kW

Environmental conditions	Temperature:	Use	+5 / +40°C
		Storage / transport	-20 / +70°C
	Humidity:	Use	20 / 80% Rh non-condensing
		Storage / transport	5 / 95% Rh non-condensing
	Atmospheric pressure:	Use	800 hPa
		Storage / transport	500 to 800 hPa (375 - 600 mm Hg)

8 LABELLING

8.1 RATING PLATE INFORMATION

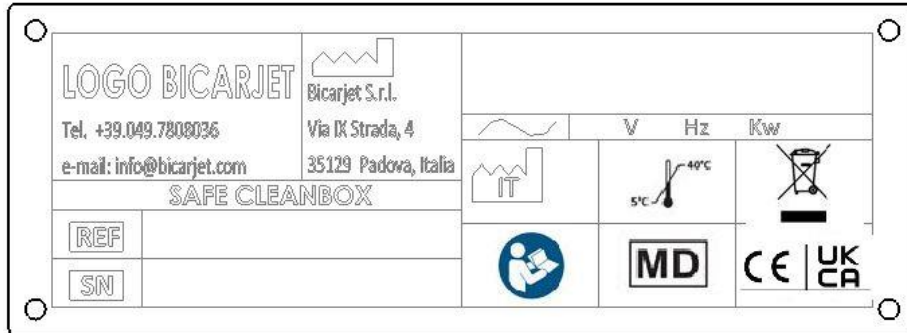

8.2 INTERNAL MARKINGS

All protective earth terminals have this marking.



8.3 WATER SUPPLY, COMPRESSED AIR AND DRAINAGE

The following marking will be located near the connection between the hydraulic circuits of the device and structure.

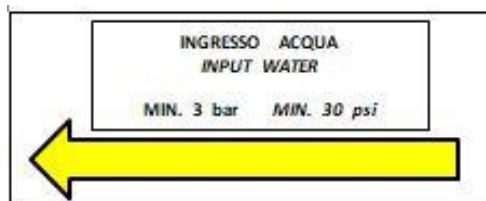

The following marking will be located near the connection between the compressed air circuit of the device and the distribution network of the structure.

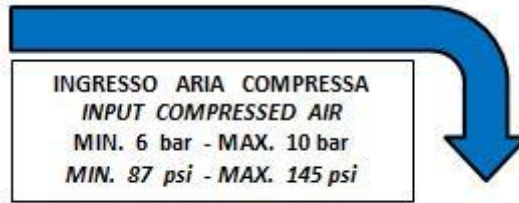

The following marking will be located near the connection with the liquid drain.



8.4 WARNING MARKINGS

The following markings are located on the door of the electrical panel.















The following signs are located near the handle and the side levers of the front door.



8.5 SAFETY SYMBOLS AND LABELLING

	Manufacturer identification
REF	Product identification code
SN	Production serial number
 YYYY/MM/DD or YYYY/MM	Country of manufacture and date of manufacture.
MD	Medical device

	Alternating current
	Earth terminal
	Dispose of according to WEEE regulations
	Consult the user manual
	Complies with Regulation (EU) 2017/745, MD class I
	Danger of: xxx (generic symbol to be associated with descriptions)
	Danger due to the presence of live parts
	Hand crushing hazard
	Direction and characteristics of flow
	Direction of the discharge flow with the presence of potentially bio-contaminating residues
	Do not use water for washing/cleaning
	SAFEKLINIC [®] bottle compartment
	Ambient operating temperature
	UK Conformity Assessed

9 ELECTROMAGNETIC COMPATIBILITY

9.1 EMC WARNINGS

The appliance complies with the collateral standard CEI EN 61326-1 applicable to the product and relating to electromagnetic compatibility.



THE APPLIANCE MUST BE INSTALLED AND COMMISSIONED ACCORDING TO THE EMC INFORMATION PROVIDED IN THIS SECTION.



THE EQUIPMENT MAY BE AFFECTED BY COMMUNICATION EQUIPMENT AND MOBILE PHONES.



THE EQUIPMENT MUST ONLY BE USED WITH THE CABLES SPECIFIED BY THE MANUFACTURER.



THE DEVICE MUST NOT BE USED NEAR OR IN COMBINATION WITH OTHER EQUIPMENT IN ORDER TO AVOID INTERFERENCE DURING NORMAL USE.

The device falls into group 1 and class A, according to the definitions of the EN 55011 standard, as follows:

- Group 1: Group 1 includes all equipment covered by the EN 55011 standard which does not fall within the definition of group 2 equipment.
- Class A: equipment suitable for use in all places other than those in residential environments and those directly connected to a low voltage power supply network for buildings put to domestic uses.

10 TUTORIAL ON CORRECT CLEANING OF THE INSTRUMENTS

The following tutorials are application examples of BICARmed technology.

10.1 DRILL TUTORIAL



Pay attention to the electrical connections, do not use the bicarbonate jet, rinse only.



Clean inside and attempt flushing. Refer to the procedure for cannulated instruments described in Tutorial 4.

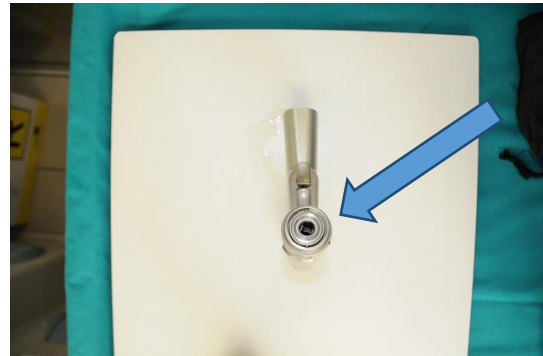

Clean inside and attempt flushing.

N.B. Rinse thoroughly. Once removed from the cabin, it is important to decontaminate.

10.2 SHIELDED CABLE - 296-4 05168



Only the steel ends can be treated, not the plastic hose.



Be careful not to treat the electrical connections. Rinse thoroughly.

10.3 SHIRT FOR LAPAROSCOPIC (CANNULATED) INSTRUMENTS

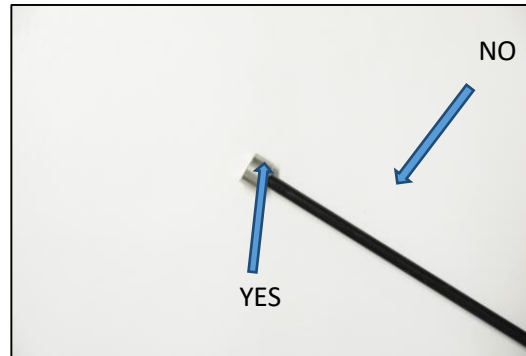
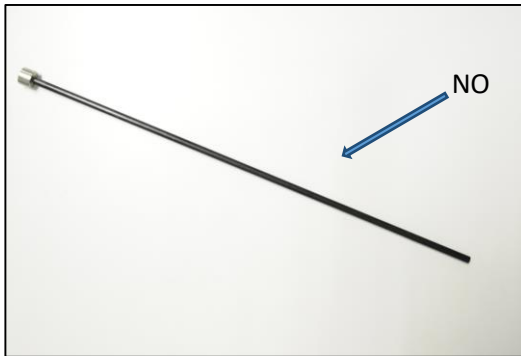

Treat the metal end. Do not treat the polymer body.

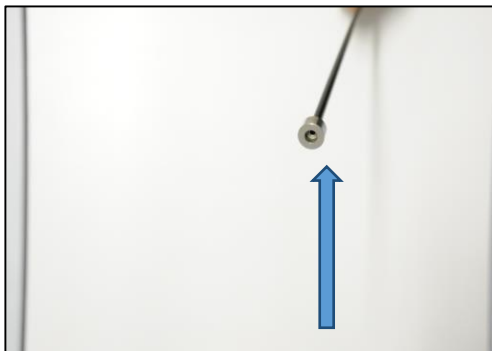

YES

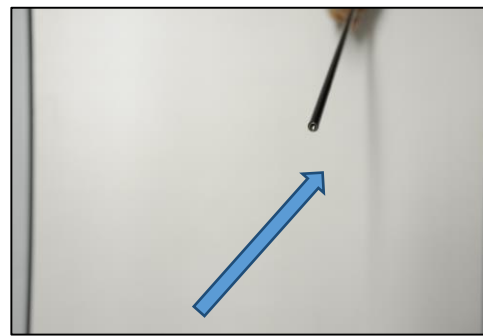

See procedure below.

10.4 PROCEDURE FOR CANNULATED INSTRUMENTS

To clean the cannulated instruments, flush water with the supplied gun to check the state of patency upon receipt (**figure 1**), repeat this operation until a minimum flush is visible

Then position the object with the inlet hole perfectly aligned with the hole in the spray nozzle at a distance of about 12-18 cm in order to facilitate entry of the product into the cannulated instrument (**figure 2**). Spray for 5-10 seconds and/or until visible filling of the product (**figure 3**), then flush the product with the water gun (**figure 1**).

In case of visible residues from the hole(s) of the outlet repeat the entire operation.



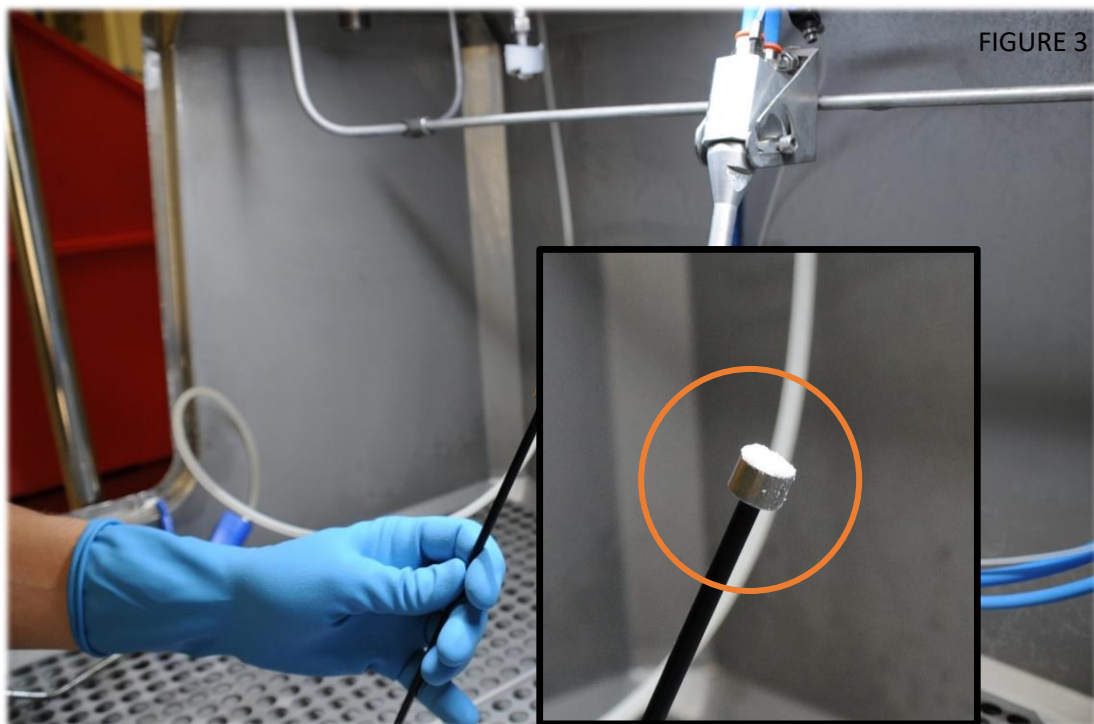
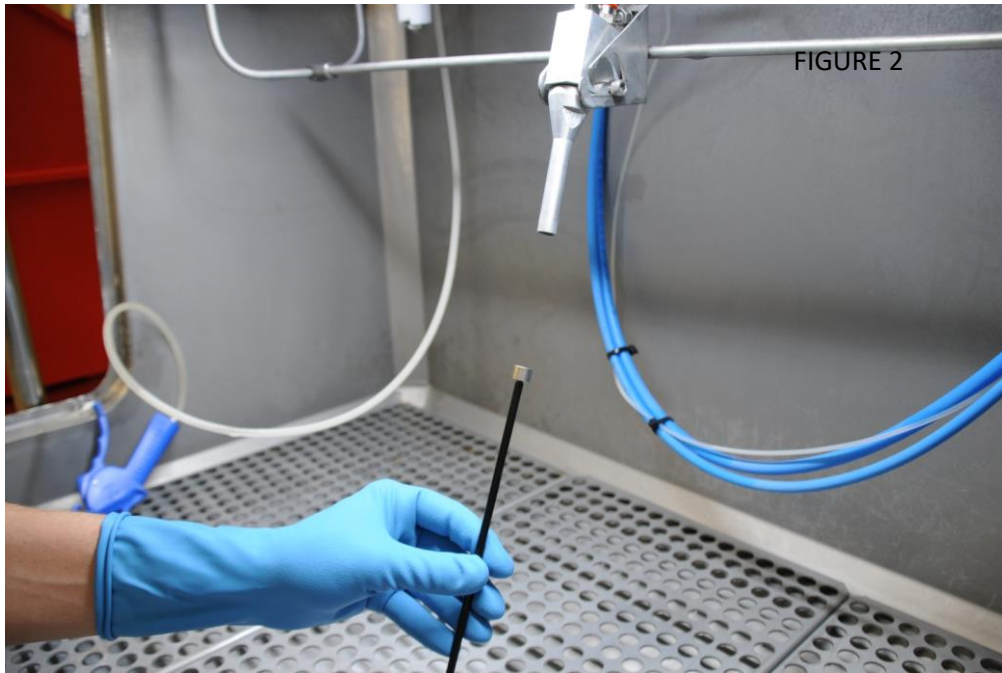

10.5 MONOPOLAR INSULATED FORCEPS

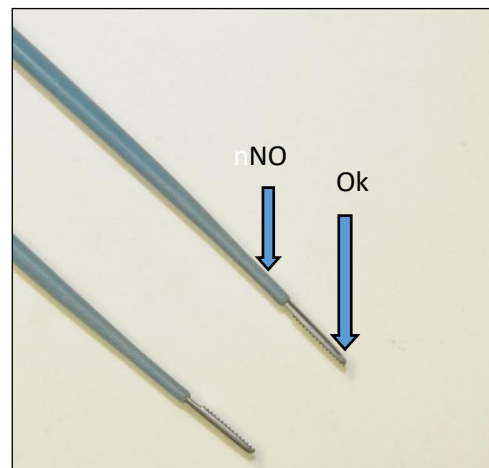
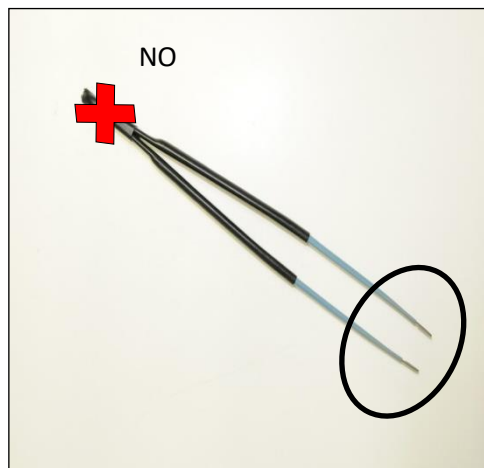

Clean the metal tips thoroughly. Do not treat the polymer handles, and do not flush the attachment point of the forceps marked with the red X in the image.

10.6 VICKERS ELEVATOR - KLS MARTIN 23-506-17

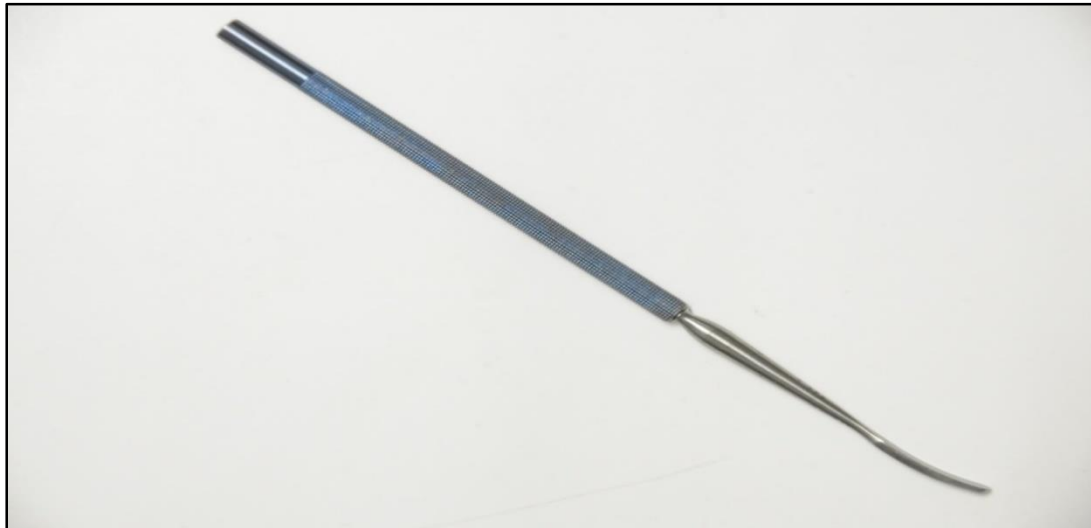

Steel instrument with titanium handle. Treat every point carefully, especially the knurls.

10.7 BONE FORCEPS - SYNTHES 398.81

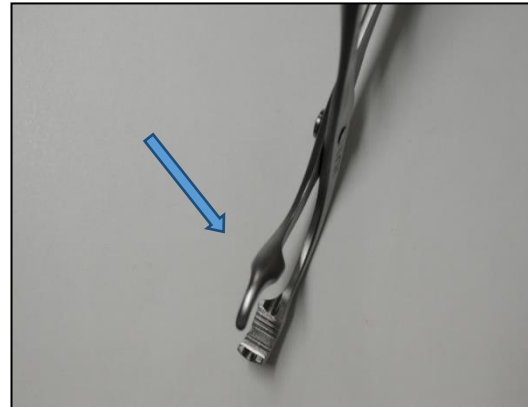
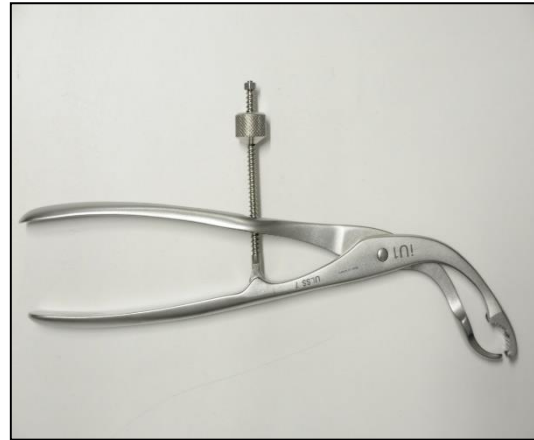
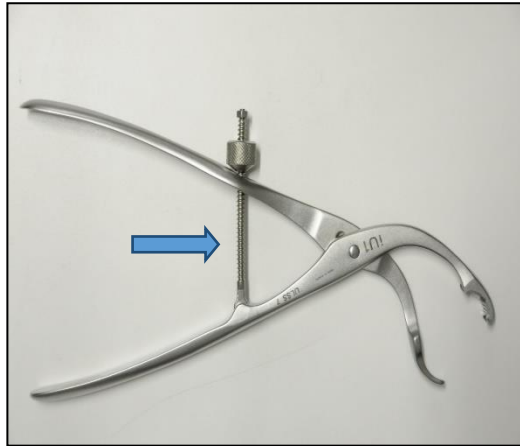

Steel instrument. Treat the entire surface, slide the bolt on the screw for ease of cleaning, focus on the knurls

10.8 BIPOLAR FORCEPS - SOFAR 82410001 / BISSINGER 82410034

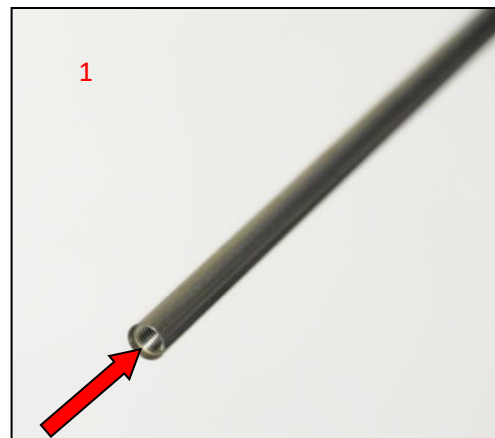
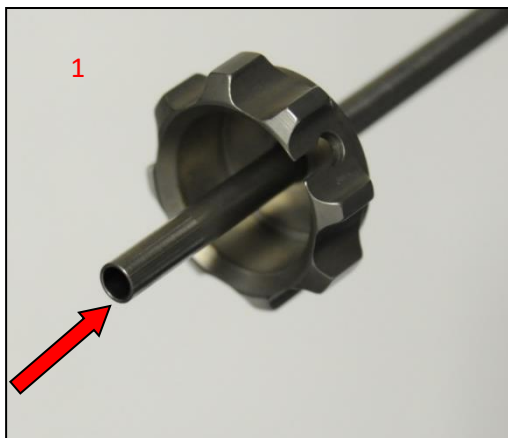

Clean inside with care and attempt flushing. Refer to the procedure for cleaning cannulated instruments described in Tutorial 4

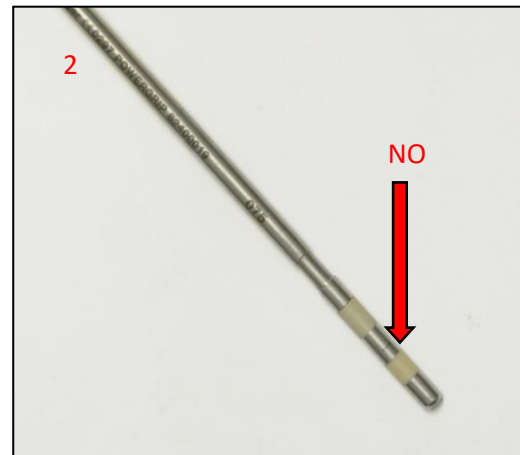
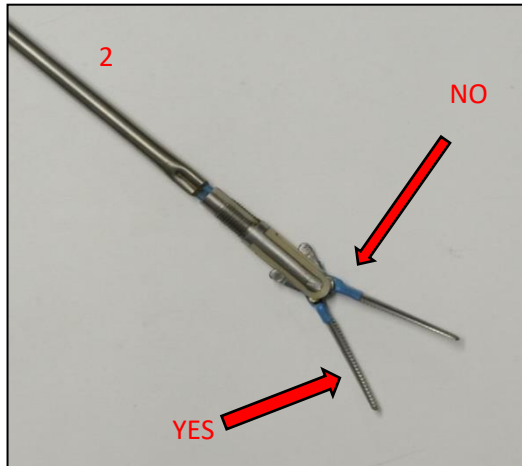

Pay attention to the plastic parts and do not treat with the jet. Treat the extremities with the utmost care.



Do not treat these directly with the jet.

Rinse thoroughly.

10.9 TEMPORARY COVER - STORZ 27 026 UO

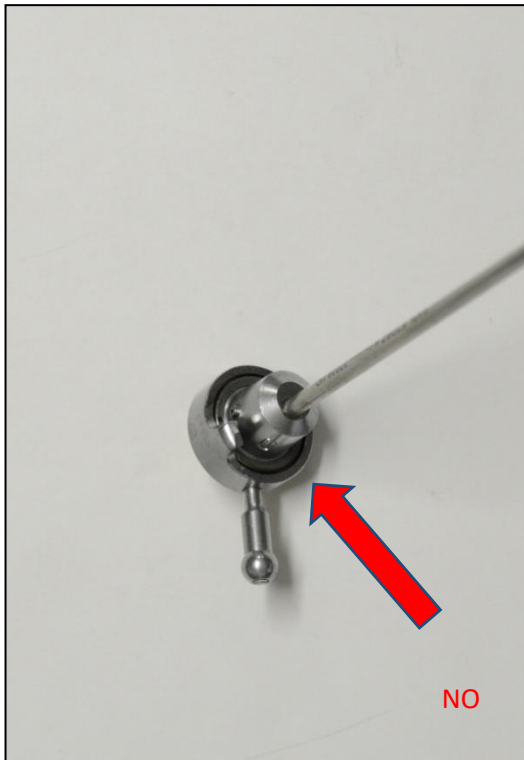
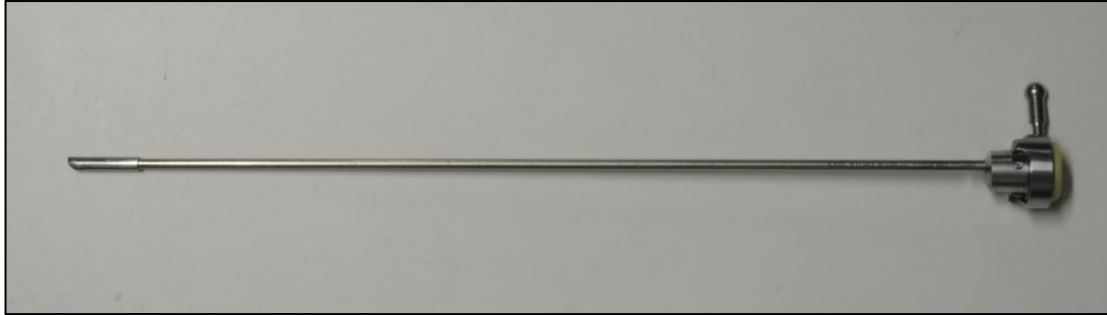

Clean with care the more complex parts where there may be residues. Do not treat the plastic part with the jet

10.10 MONOPOLAR HOOK FOR COAGULATION



Be careful not to treat the inside of the compartment with the jet (because it is made of plastic), but only rinse thoroughly

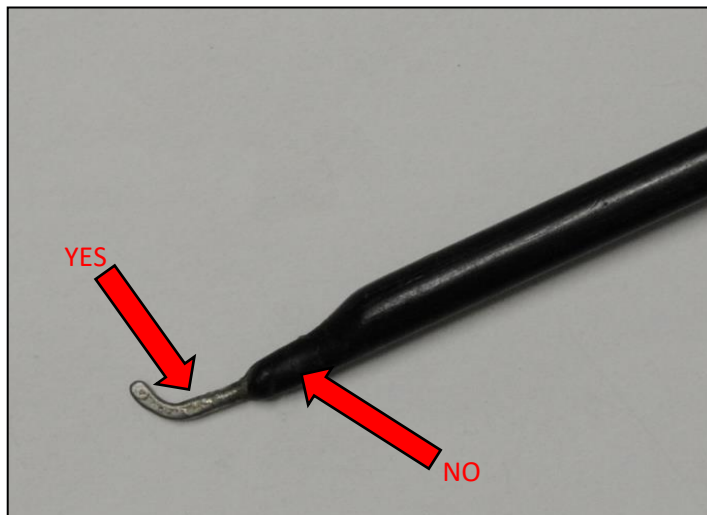

10.11 BIPOLAR FORCEPS - MICRO FRANCE CEV 136

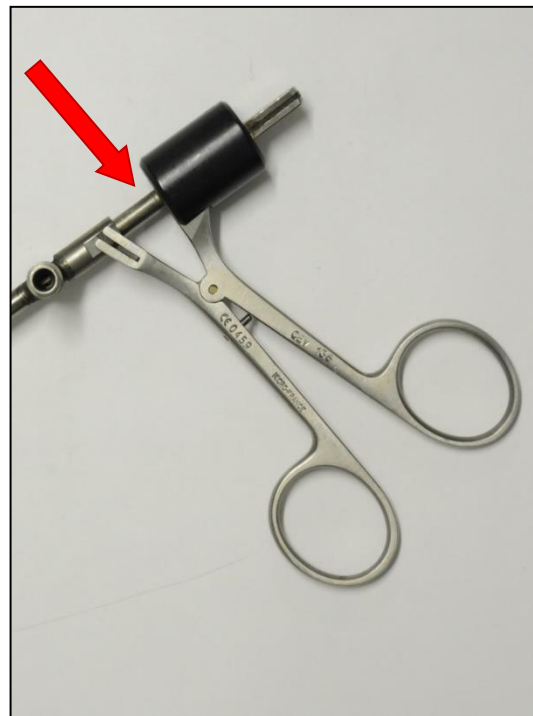

Slide the mechanism in order to also remove any residues inside.

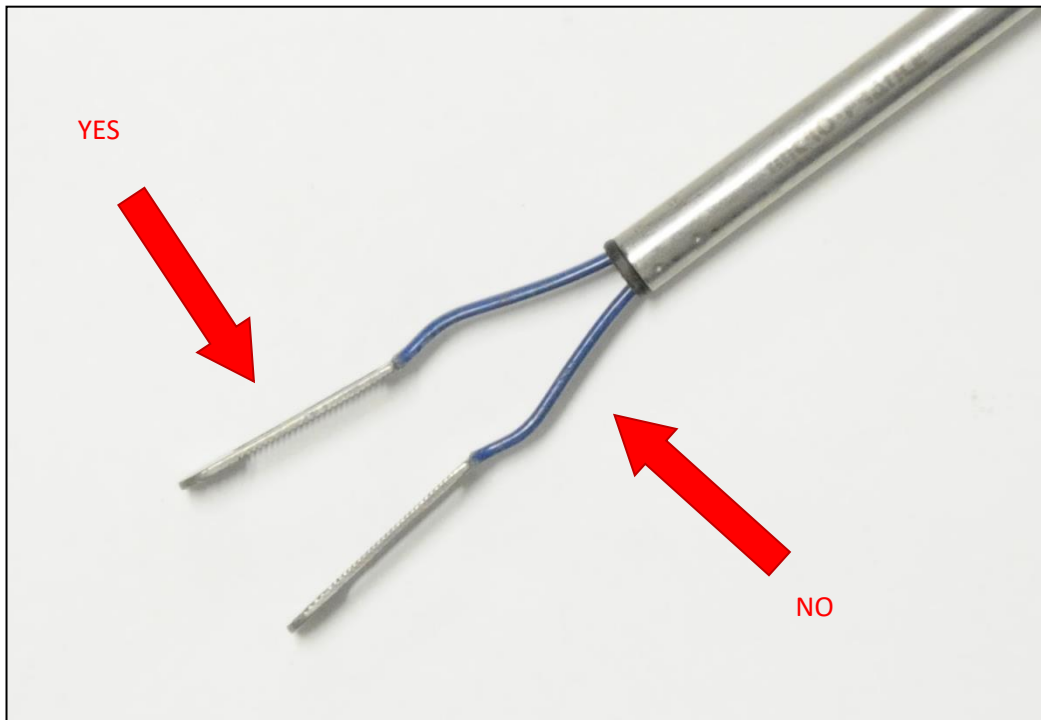

Do not treat the plastic parts with the jet.

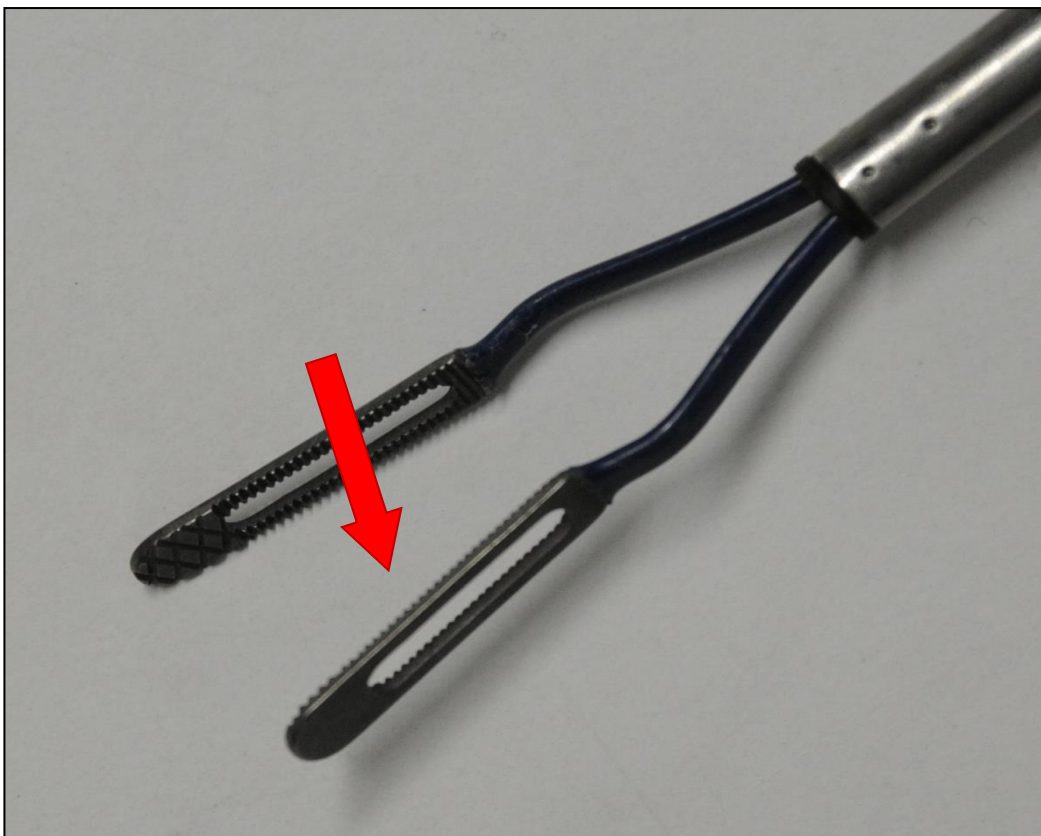

Treat the knurls on the ends carefully.

10.12 MONOPOLAR FORCEPS - REMA 28 - 247 - 000



Do not treat the plastic body with the jet. Disassemble the various parts in order to treat the metal points and rinse the plastic parts with water.

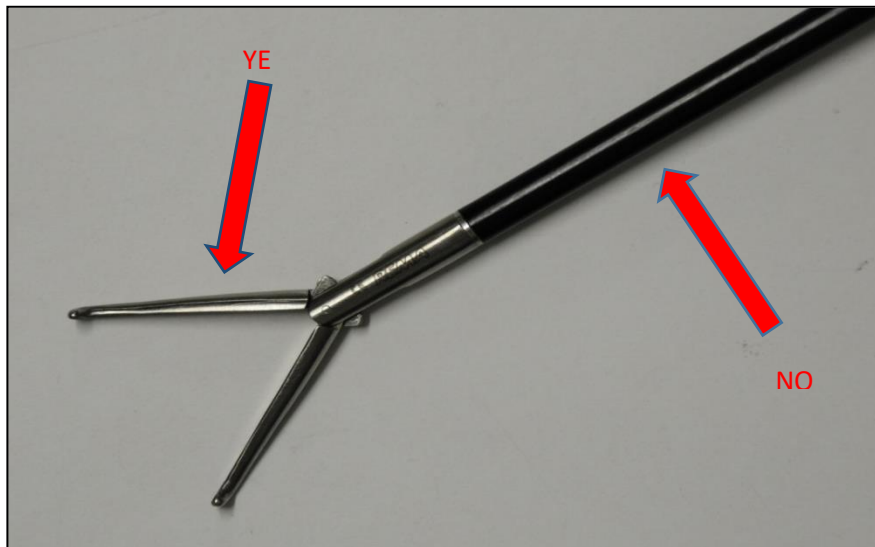

Be careful not to treat the plastic parts; clean only the metal tip with the jet.

10.13 CYSTOSCOPY SHIRT - STORZ 27 026 B



10.14 OBJECT ENTIRELY IN METAL. TREAT WITH THE JET IN FULL.

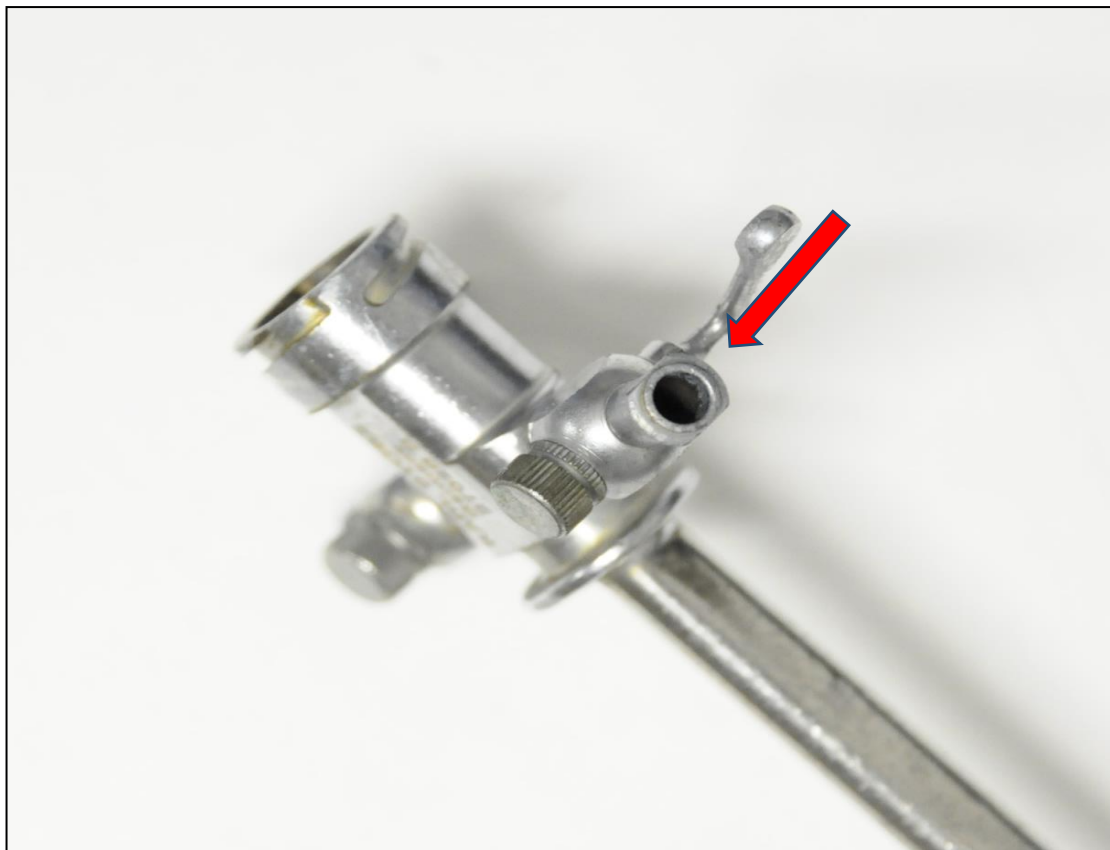

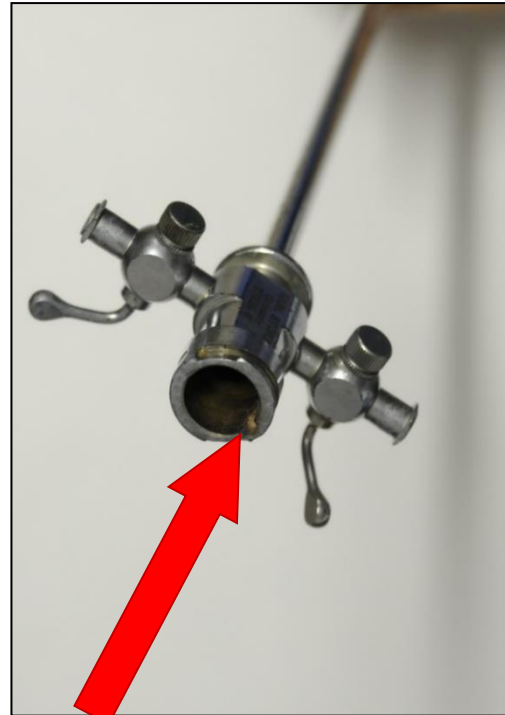

Carefully clean all the critical points of the object. Clean the inside of the cannulated instrument and attempt flushing. Follow the procedure described in tutorial 4.

10.15 OBJECT X - MITEK 214615

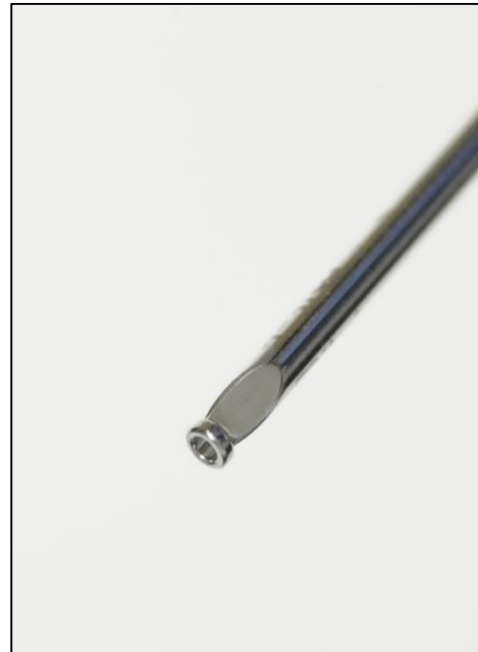

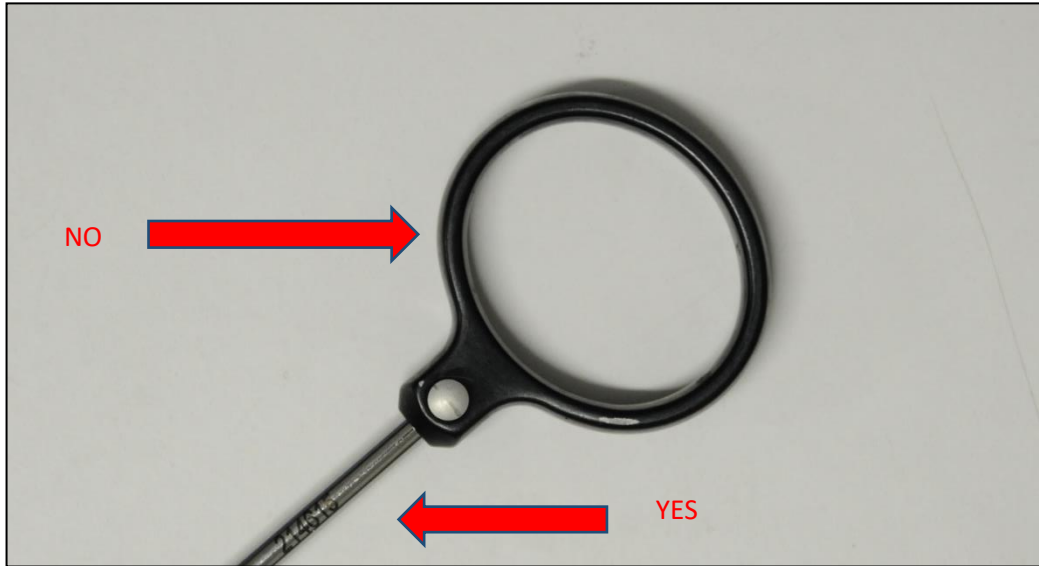

The coloured material (anodized aluminium) can be treated but with caution: keep a distance of at least 10/15 cm and make contact for a very short time (1/2 seconds).

10.16 ARTHROSCOPY FORCEPS - MITEK 214602

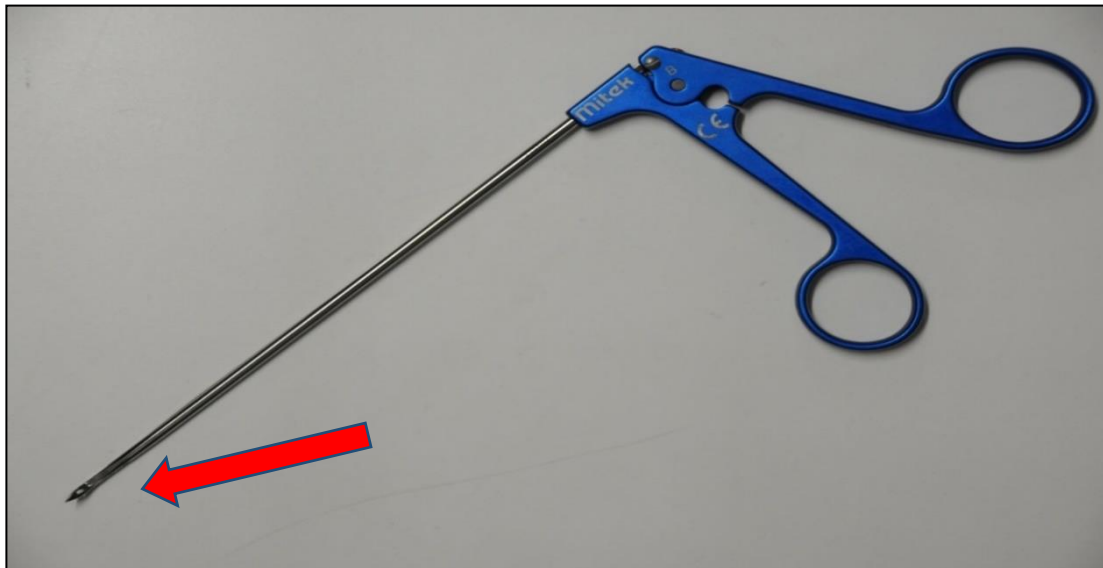

Carefully clean the ends

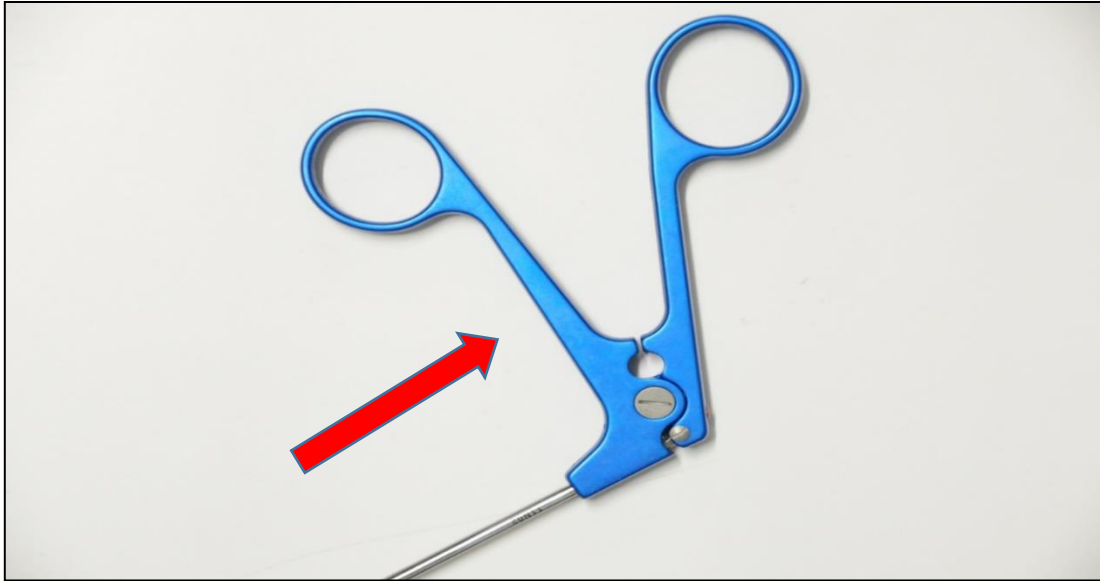

The coloured material (anodized aluminium) can be treated but with caution: keep a distance of at least 10/15 cm and make contact for a very short time (1/2 seconds).

10.17 KARL STORZ TROCAR 30160 H2 (CANNULA WITH STOPCOCK)



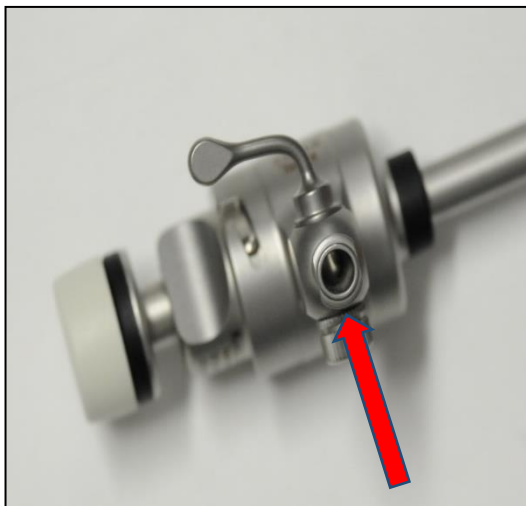
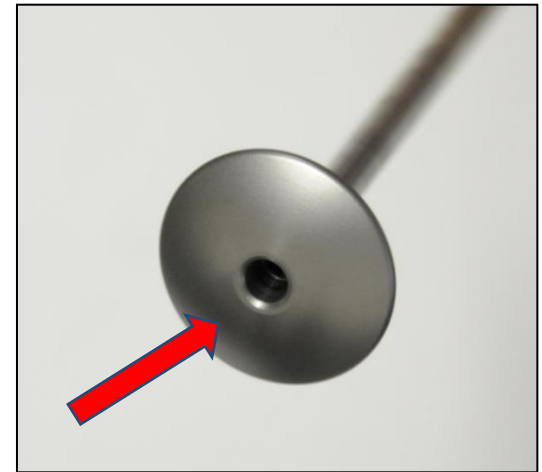
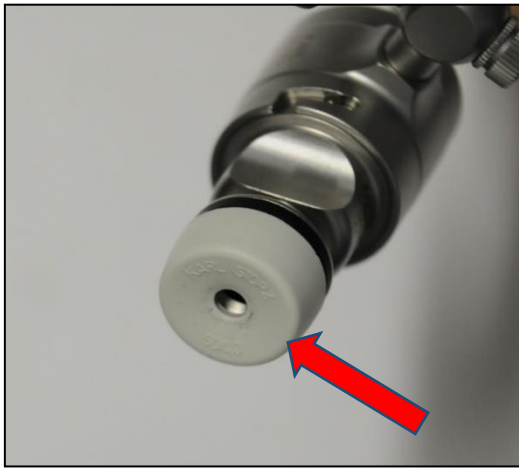
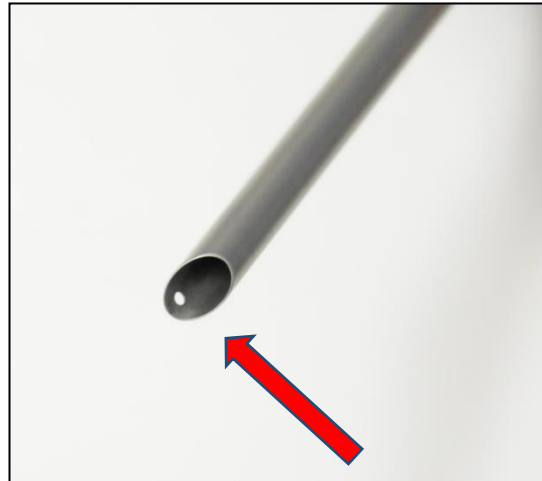

Carefully clean the ends and, where possible, attempt flushing (for cleaning the cannulated instruments refer to the procedure described in tutorial 4). Be careful not to treat the plastic parts.

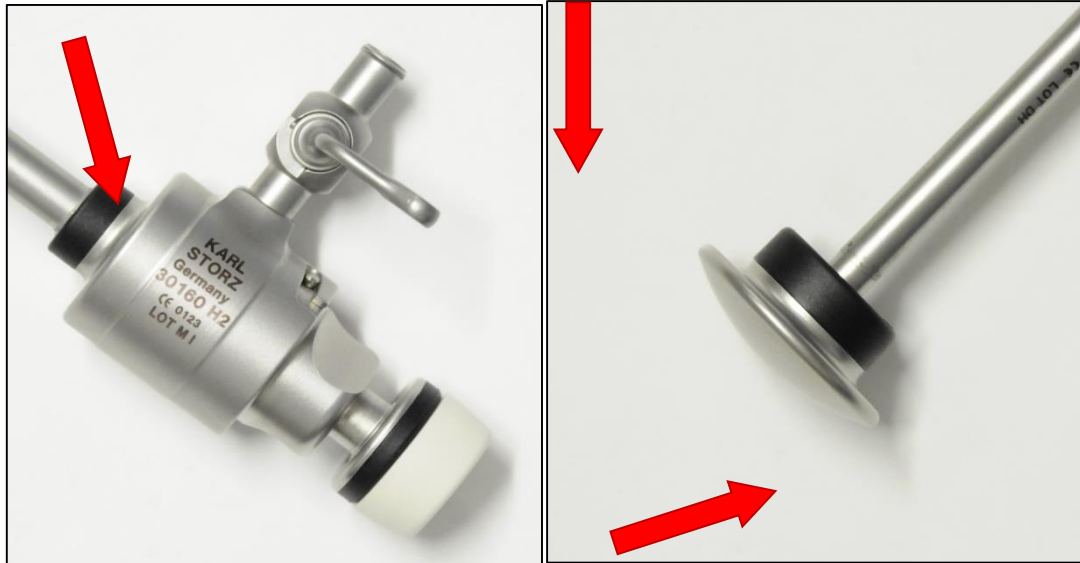

Do not treat the coloured plastic parts with the jet.

10.18 EYE MICROSURGERY KIT - STEEL

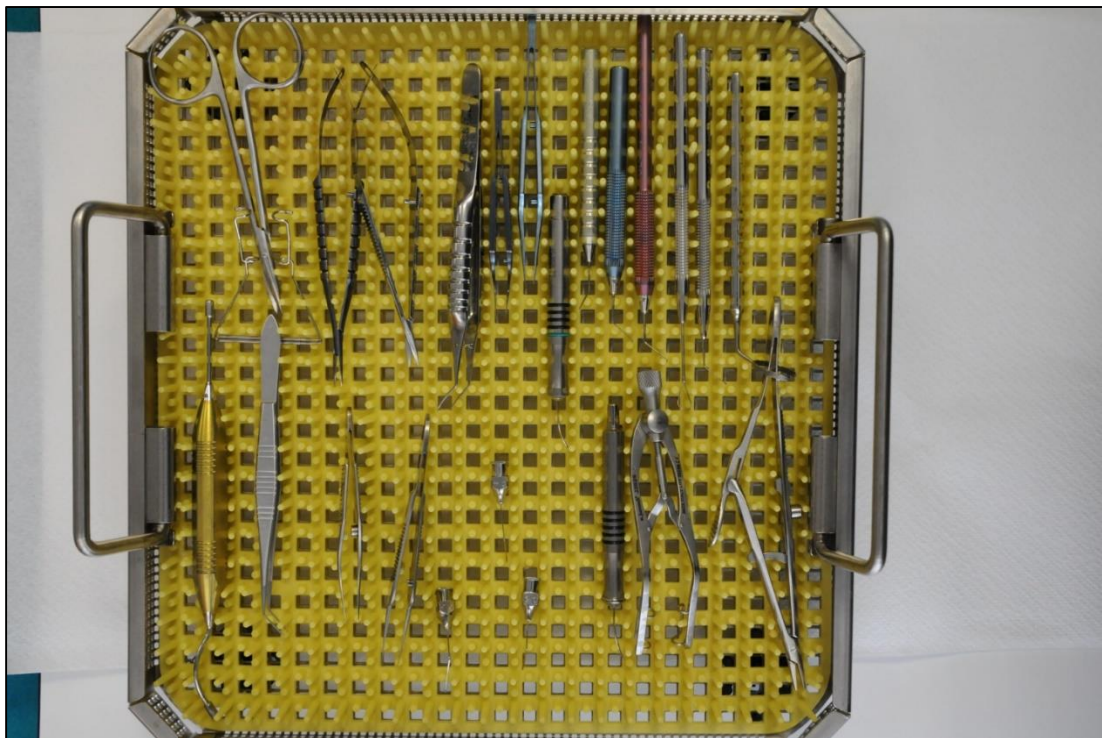

PROCEDURE: the kit is treated with bicarbonate directly in its container. After a first passage of about 60 seconds, the instruments are turned and retreated.

N.B.: (ON THE THINNER NEEDLES) follow the procedure in tutorial 4 for cannulated instruments.

After cleaning with bicarbonate, rinse thoroughly to remove any visible residue.

10.19 KARL STORZ ROD-LENS SYSTEM 27005AA

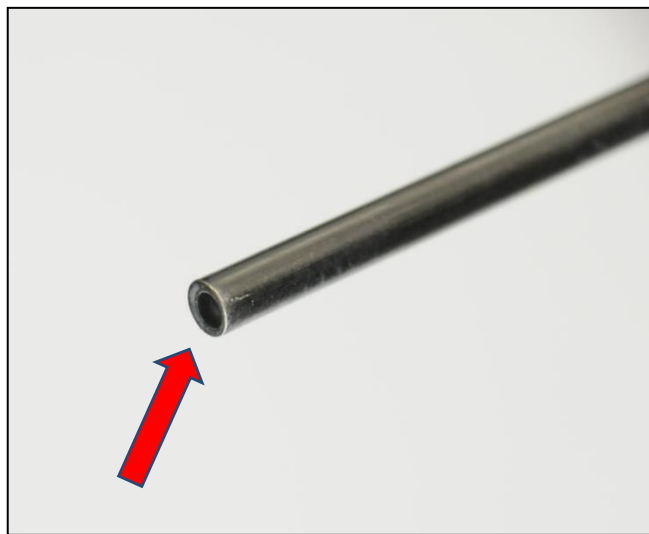





Procedure for cleaning the lens: Treat the area indicated by the arrow Very close distance, 2-5 cm Time: 60 seconds.

11 SW MANUAL - HMI PANEL

11.1 MACHINE READY - HOME SCREEN

BICAR_{med} 19/01/22 WED 14:22:02
User: **Reparto**

MACHINE IN STAND-BY





WASHING 	RINSING 	 
---	---	--

Bicarbonate	water flow	Air presence
0 oz	0.00 gal/min	

11.2 LAVAGGIO ATTIVO (ACTIVE WASHING) SCREEN

BICAR_{med} 19/01/22 WED 14:26:16
User: **Reparto**

WASHING CYCLE





WASHING 	RINSING 	 
---	---	--

Bicarbonate	water flow	Air presence
0 oz	0.00 gal/min	

11.3 RISCIACQUO ATTIVO (ACTIVE RINSING) SCREEN

BICAR_{med} 20/01/22 THU 08:25:00
User: **Reparto**





RINSE CYCLE

WASHING 	RINSING 	 
Bicarbonate 0.000 oz	water flow 0.00 gal/min	

11.4 MACCHINA IN EMERGENZA (MACHINE IN EMERGENCY MODE) SCREEN

BICAR_{med} 19/01/22 WED 15:12:15
User: **Reparto**

EMERGENCY

WASHING 	RINSING 	  
Bicarbonate 0 oz	water flow 0.00 gal/min	

11.5 SETTINGS/MENU SCREEN

To access the menu

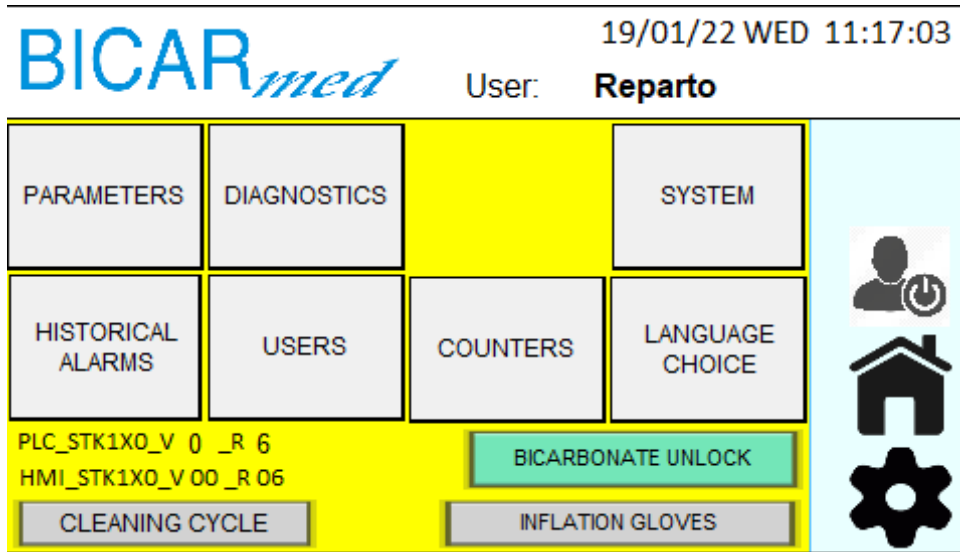

11.6 SISTEMA (SYSTEM) SCREEN

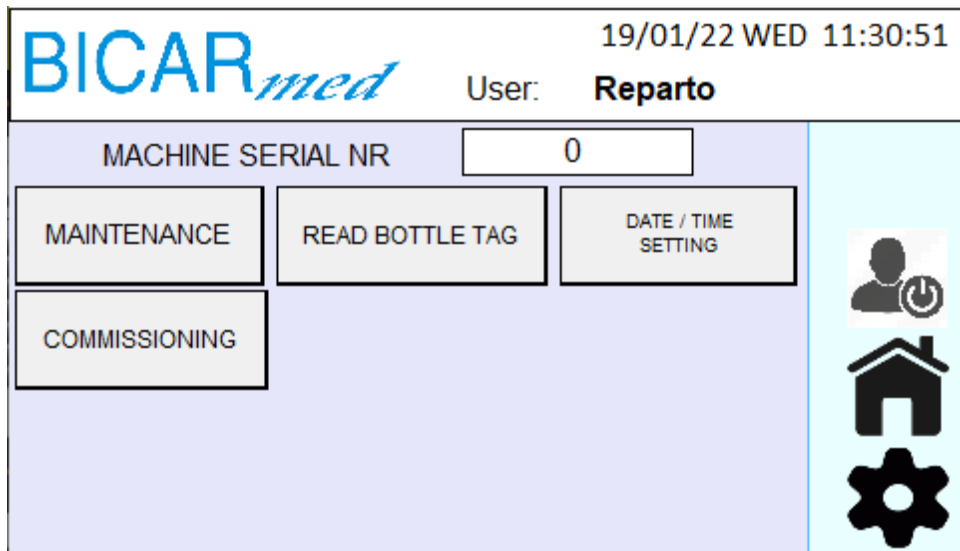

11.7 DATE AND TIME SETTING SCREEN

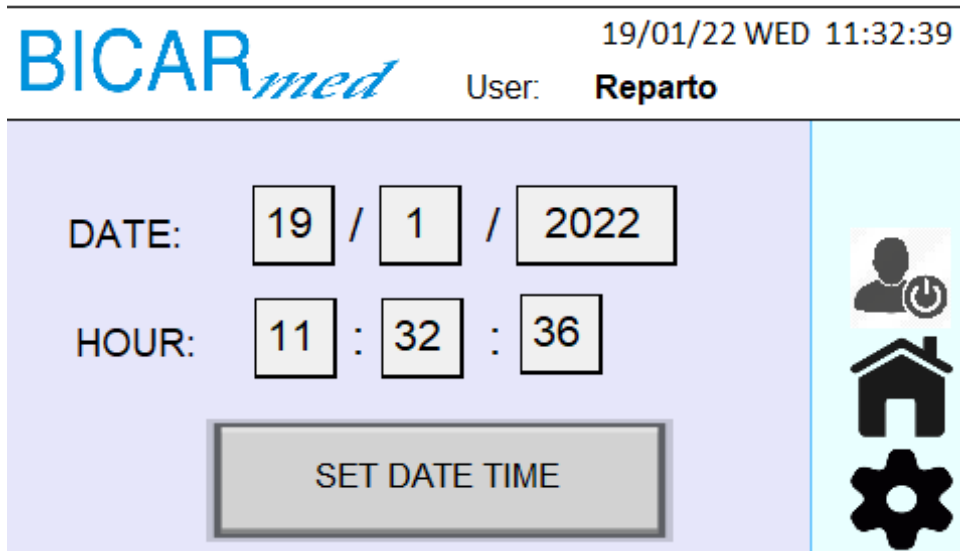

11.8 DIAGNOSTICA (DIAGNOSTICS) SCREENS

BICAR_{med} 19/01/22 WED 11:29:11
User: **Reparto**

INGRESSI

<input type="checkbox"/> Thermal Water Drain	<input type="checkbox"/> Emergency button
<input type="checkbox"/> Therma Isuction unit	<input type="checkbox"/> Water flow switch
<input type="checkbox"/> Washing pedal	<input type="checkbox"/> Alarm Reset Button
<input type="checkbox"/> Rinsing pedal	<input type="checkbox"/> Emergency on
<input type="checkbox"/> Air pressure switch	<input type="checkbox"/> Emergency doors on
<input type="checkbox"/> Water level bin	<input type="checkbox"/> Valve group alarm
<input type="checkbox"/> Max Bin Water Level	<input type="checkbox"/> ---
<input type="checkbox"/> ---	

BICAR_{med} 01/02/22 TUE 08:23:08
User: **Tecnico**

USCITE

<input type="checkbox"/> Alarm Reset light	<input type="checkbox"/> EV Exhaust Valve Open
<input type="checkbox"/> Cabin lighting	<input type="checkbox"/> EV Rinsing Water
<input type="checkbox"/> Windscreen wiper	<input type="checkbox"/> EV Air Rinsing
<input type="checkbox"/> Buzzer	<input type="checkbox"/> EV Water Washing
<input type="checkbox"/> EV Water Bin	<input type="checkbox"/> EV Air Washing
<input type="checkbox"/> Water drain pump	<input type="checkbox"/> EV Water Windscreen Wiper
<input type="checkbox"/> Suction motor	<input type="checkbox"/> ---
<input type="checkbox"/> Low speed suction unit	

11.9 PARAMETRI (PARAMETERS) SCREEN

BICAR_{med} 19/01/22 WED 11:46:35
 User: **Tecnico**

Water emptying stop delay	20.0 s
Nozzle transport opening delay	5.0 s
Nozzle water opening delay	0.0 s
Nozzle transport closing delay	1.0 s
Low bicarbonate level	0.0 oz
Insufficient bicarbonate level	0.0 oz
Maximum weight increase	0.0 oz
Time before Stand-By	2 min
Time before Logout	5 min



BICAR_{med} 19/01/22 WED 11:46:56
 User: **Tecnico**

Time before no water alarm	5.0 s
Waiting time for wiper switch-on	0.5 s
Windscreen water shutdown time	2.0 s
Glove inflation cycle time	15.0 s
Average consumption Bicarbonate set	0 oz/min
Average bicarbonate tolerance	0 oz/min
Weight Bicarbonate Bottle	0 oz



BICAR_{med} 19/01/22 WED 11:47:19
 User: **Tecnico**

Number of bicarbonate release puffs	5
Duration of bicarbonate release puffs	0.1 s
Interval between puffs	1.0 s
Minimum washing water flow level	0.0 gal/min
Minimum rinse water flow level	0.0 gal/min
Air opening time bicarbonate before unlocking	1.0 s
	0.0 oz



11.10 CICLO PROVA (TEST CYCLE) SCREENS

BICAR_{med} 19/01/22 WED 11:49:00
User: **Tecnico**

<input checked="" type="checkbox"/> SUCTION UNIT	<input checked="" type="checkbox"/> Bin Unloading
<input checked="" type="checkbox"/> Rinsing water	<input checked="" type="checkbox"/> Water injection
<input checked="" type="checkbox"/> Air Rinsing	
<input checked="" type="checkbox"/> Bicarbonate water	CYCLE TIME <input type="text" value="10.0 s"/>
<input checked="" type="checkbox"/> Air Bicarbonate	

Past time Remaining time

11.11 REGISTRO ALLARMI (ALARMS REGISTER) SCREEN

BICAR_{med} 19/01/22 WED 11:53:47
User: **Tecnico**

01/19/22	09:55:10	22-COMUNICAZIONE CON DISP. DI PESATURA
01/19/22	10:16:31	22-COMMUNICATION WITH WEIGHING DEVICE
01/19/22	10:21:22	22-COMUNICAZIONE CON DISP. DI PESATURA
01/19/22	10:31:29	22-COMUNICAZIONE CON DISP. DI PESATURA
01/19/22	10:51:31	22-COMUNICAZIONE CON DISP. DI PESATURA
01/19/22	11:01:39	22-COMUNICAZIONE CON DISP. DI PESATURA
01/19/22	11:11:48	22-COMUNICAZIONE CON DISP. DI PESATURA
01/19/22	11:22:00	22-COMMUNICATION WITH WEIGHING DEVICE
01/19/22	11:22:00	22-COMMUNICATION WITH WEIGHING DEVICE
01/19/22	11:22:06	22-COMMUNICATION WITH WEIGHING DEVICE
01/19/22	11:32:13	22-COMMUNICATION WITH WEIGHING DEVICE
01/19/22	11:43:59	22-COMMUNICATION WITH WEIGHING DEVICE

12 ANNEX 01: PRE-SET USERS/PASSWORDS

The machine is supplied with a pre-set number of user accounts for personnel trained to use the machine.

These include:

No. 1 user HEAD OF DEPARTMENT
No. 8 users OPERATOR

The PASSWORDS are pre-set for these users.

The OPERATOR user password only enables the use of the machine.

The HEAD OF DEPARTMENT user password enables the use of the machine and allows some additional functions, such as entering a new USER.

IMPORTANT:

We suggest that you create new user accounts with Personalized Passwords for the customer.

Pre-set Passwords:

User	Password
department	00000
01	11111
02	22222
03	33333
04	44444
05	55555
06	66666
07	77777
08	88888

13 ANNEX 02: HOSE CONNECTIONS INSIDE THE CABIN

Connections of the handpiece hoses to the fittings on the wall inside the cabin.

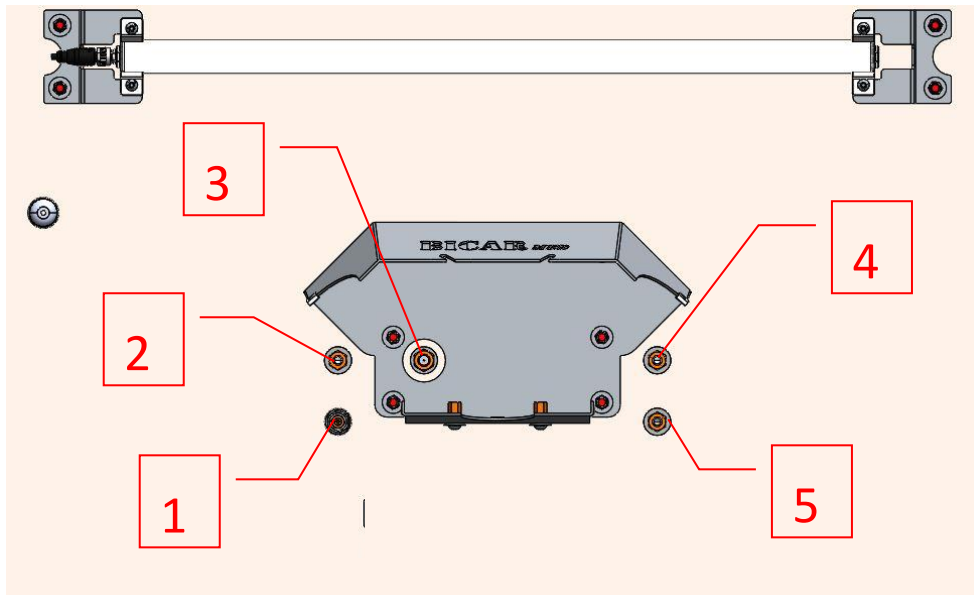

WASHING HANDPIECE (GREY)

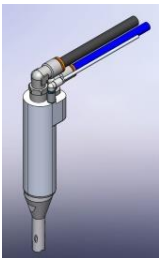

- 1) HOSE \varnothing 3x2 TRANSPARENT –WATER-
- 2) HOSE \varnothing 8x5 BLUE –AIR-
- 3) HOSE \varnothing 10x6.5 BLACK –BICARBONATE-

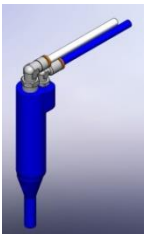

RINSING HANDPIECE (BLUE)

- 4) HOSE \varnothing 8x6 TRANSPARENT –WATER-
- 5) HOSE \varnothing 8x6 BLUE –AIR-